

fiorentini

S 32 B

PARTI DI RICAMBIO
SPARE PARTS
PIECES DETACHEES
ERSATZTEILE



**ING. O. FIORENTINI
INDUSTRIAL CLEANING MACHINE**

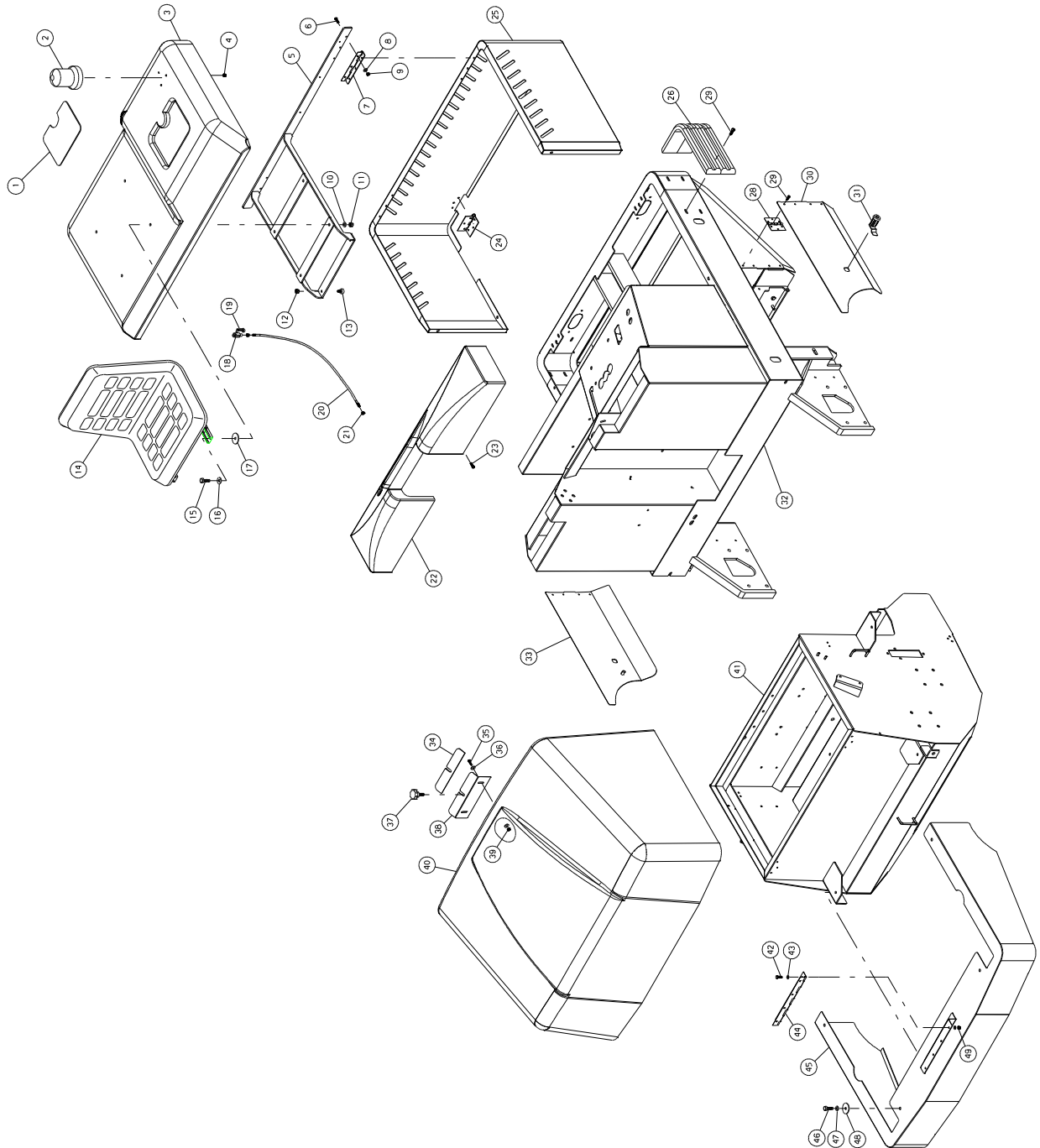

N.Position	Code Num	Qta	Descrizione	Description	Description	Bezeichnung
32B.01.001	MT-BP5057	1	GOMMA PRISMATA PORTAOGGETTI S32	*****	*****	*****
32B.01.002	MT-PY7005	1	LAMPEGGIANTE MULTIVOLTAGGIO	BLINKER	GYROPHARE	BLINKLEUCHTE
32B.01.003	MT-CA5026	1	COFANO POSTERIORE S32	*****	*****	*****
32B.01.004	MT-DD251	3	DADO AUTOBLOCCANTE M4	*****	*****	*****
32B.01.005	MT-SU5207	1	TELAIO SUPPORTO SEDILE S32	*****	*****	*****
32B.01.006	MT-VV5002	6	VITE TESTA BOMBATA M6x10	CUP-HEADED BOLT	VIS	HALBRUNDSCHRAUBE
32B.01.007	MT-MV5066	2	CERNIERA SUP. COFANO POST. S32	*****	*****	*****
32B.01.008	MT-RO203	6	RONDELLA NORMALE DIAM. 6 UNI 6592/6	WASHER D6	RONDELLE	SCHEIBE
32B.01.009	MT-DD204	6	DADO M6 UNI 5588/65	NUT	ECROU	MUTTER
32B.01.010	MT-RO204	4	RONDELLA PIANA M8	WASHER	RONDELLE	SCHEIBE
32B.01.011	MT-DD205	4	DADO M8 UNI 5588/65	NUT	ECROU	MUTTER
32B.01.012	MT-DD204	2	DADO M6 UNI 5588/65	NUT	ECROU	MUTTER
32B.01.013	MT-MI2509	2	ANTIVIBRANTE 18x7,5 M6 (TAMPONE)	VIBRATION-DAMPING	ANTIVIBRATOIRE	ERSCHUTTERUNGSFREIER
32B.01.014	MT-MI015	1	SEDILE COMPLETO DI GUIDE	SEAT	SIEGE	SITZ
32B.01.015	MT-VV5000	4	VITE TESTA BOMBATA M8x30	CUP-HEADED BOLT	VIS	HALBRUNDSCHRAUBE
32B.01.017	MT-RO302	4	RONDELLA SLARG.DIAM. 8x24 UNI 6592/	WASHER	RONDELLE	SCHEIBE
32B.01.018	MT-MI5099	1	FORCELLA LUNGA M6	LONG FORK M6	FOURCHETTE LONGUE M6	GABEL
32B.01.019	MT-MI5100	1	CLIPS PER FORCELLA 6X24	FORK CLIPS	PATTE	SHELLE
32B.01.020	MT-MI5053	1	FUNE DI TENUTA CASSONE	BODY ROPE	CORDE DU CONTENEUR DE	STAHLDRAHTSEIL
32B.01.021	MT-DD204	1	DADO M6 UNI 5588/65	NUT	ECROU	MUTTER
32B.01.022	MT-CA5027	1	CRUSCOTTO COMANDI S32	*****	*****	*****
32B.01.023	MT-VV5003	4	VITE TESTA BOMBATA M4x10	CUP-HEADED BOLT	VIS	HALBRUNDSCHRAUBE
32B.01.024	MT-MI5068Z	2	CERNIERA ZINCATA COFANO POST. S32	*****	*****	*****
32B.01.025	MT-LM5230	1	LAMIERA COFANO POSTERIORE S32	*****	*****	*****
32B.01.026	MT-BU2500	2	BUMPER PARACOLPI 1mt 65x20	BUMPER	BUMPER HEURTOIR	BUMPER
32B.01.028	MT-MI5069	4	CERNIERA SPORTELLO	DOOR HINGE	CHARNIERE PORTIERE	SCHARNIER
32B.01.029	MT-VV433	12	VITE SVAS. BRUGOLA M6x25 UNI5933/77	*****	*****	*****
32B.01.030	MT-LM5213	1	LAMIERA SPORTELLO SX SPAZZOLA CENTR	*****	*****	*****
32B.01.031	MT-MV5065	2	CHIUSURA SPORTELLI SOUTHCO	*****	*****	*****
32B.01.032	MT-TP5080	1	TELAIO BASE S32	*****	*****	*****
32B.01.033	MT-LM5220	1	LAMIERA SPORTELLO DX SPAZZOLA CENTR	*****	*****	*****
32B.01.034	MT-BP5061	1	GOMMA PER LAMIERA CHIUSURA COD.LM51	*****	*****	*****
32B.01.035	MT-VV5004	4	VITE TESTA BOMBATA M6x20	CUP-HEADED BOLT	VIS BOMBEE	HALBRUNDSCHRAUBE
32B.01.036	MT-RO301	4	RONDELLA SLARGATA.6x18 UNI 6592/69	WASHER	RONDELLE	SCHEIBE
32B.01.037	MT-VP5001	1	POMELLO M8X15	KNOB	POMMEAU	KUGELGRIFF
32B.01.038	MT-LM5129	1	LAMIERA CHIUSURA COFANO ANTERIORE	*****	*****	*****
32B.01.039	MT-DD204	2	DADO M6 UNI 5588/65	NUT	ECROU	MUTTER
32B.01.040	MT-CA5028	1	COFANO ANTERIORE S32	*****	*****	*****
32B.01.041	MT-TP5078	1	CASSONE S32	*****	*****	*****
32B.01.042	MT-VE242	4	VITE ESAGONALE M6x12 UNI 5737/77	SCREW	VIS	SCHRAUBE
32B.01.043	MT-RO203	8	RONDELLA NORMALE DIAM. 6 UNI 6592/6	WASHER D6	RONDELLE	SCHEIBE
32B.01.044	MT-MV5070	1	CERNIERA SUP. COFANO ANT. S32	*****	*****	*****
32B.01.045	MT-LM5223	1	PARAURTI ANTERIORE S32	*****	*****	*****
32B.01.046	MT-VE261	4	VITE TE M8x20	SCREW	VIS	SCHRAUBE
32B.01.047	MT-RO255	4	RONDELLA SPACCATI DIAM. 8 UNI 1751	WASHER	RONDELLE	SCHEIBE
32B.01.048	MT-RO204	4	RONDELLA PIANA M8	WASHER	RONDELLE	SCHEIBE
32B.01.049	MT-DD204	4	DADO M6 UNI 5588/65	NUT	ECROU	MUTTER

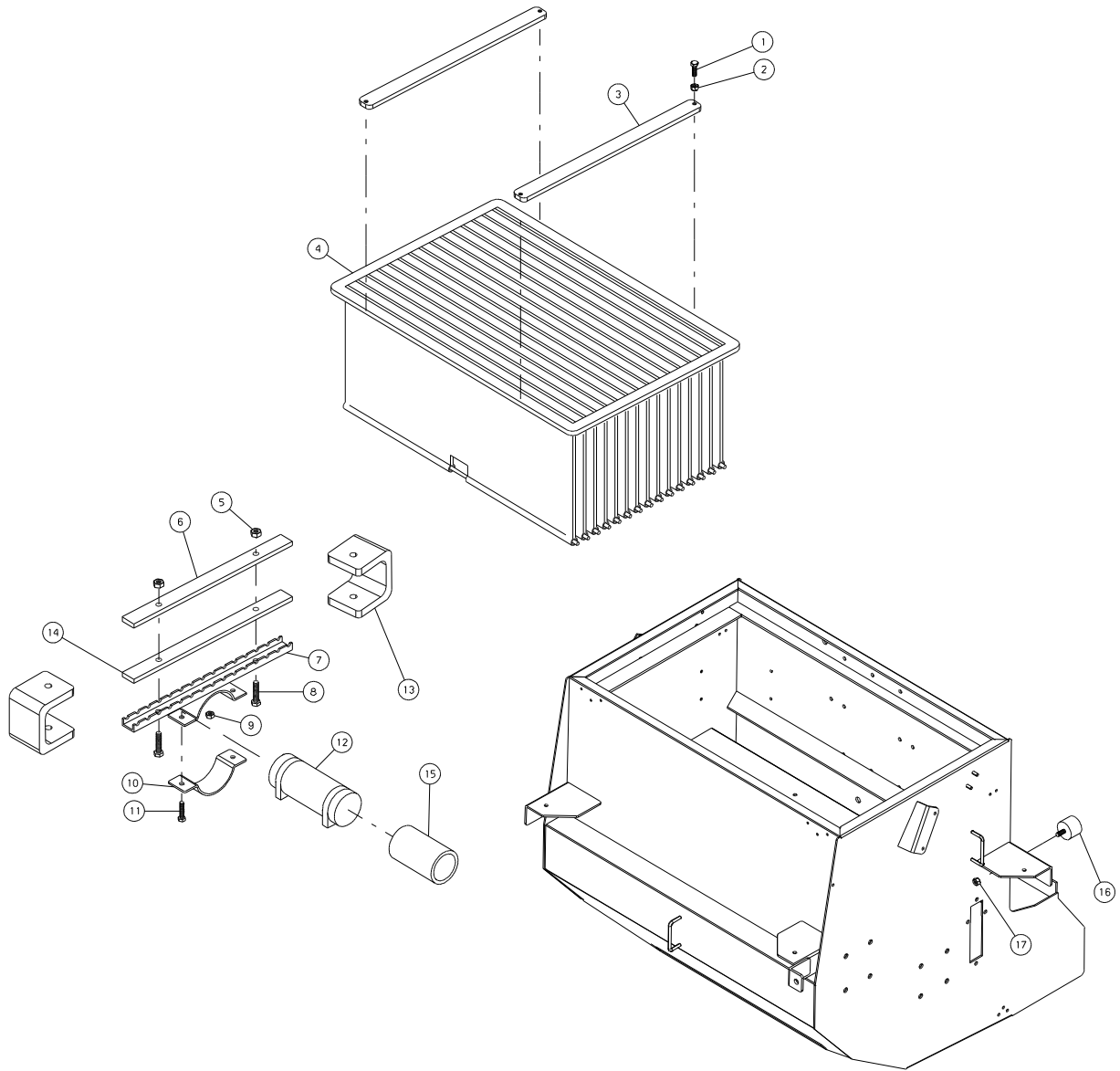



N.Position	Code Num	Qta	Descrizione	Description	Description	Bezeichnung
32B.02.001	MT-VE262	4	VITE ESAGONALE M8x25 UNI 5137/77	SCREW	VIS	SECHSECKIGE SCHRAUBE
32B.02.002	MT-DD5012	4	DADO BASSO M8	NUT	ECROU	NIEDRIGMUTTER
32B.02.003	MT-LM5135	2	LISTELLO FISSAGGIO FILTRO	FIXING FILTER BAR	LATTE DE FIXAGE FILTR	LEISTE
32B.02.004	MT-FT5040	1	FILTRO A SACCHE COMPLETO S32	*****	*****	*****
32B.02.005	MT-DD254	4	DADO AUTOBLOCCANTE M8	SELF-LOCKING NUT	ECROU DE SURETE	SICHERUNGSMUTTER
32B.02.006	MT-ST5028	1	STAFFA SUPPORTO VIBRATORE	BRACKET	BRIDE DE SUPPORT VIBR	BUEGEL
32B.02.007	MT-SU5142	1	SUPPORTO VIBRATORE INFERIORE	VIBRATOR SUPPORT	SUPPORT VIBRATEUR INF	STUETZE
32B.02.008	MT-VE267	4	VITE ESAGONALE M8x50 UNI 5737/77	SCREW	VIS	SCHRAUBE
32B.02.009	MT-DD254	2	DADO AUTOBLOCCANTE M8	SELF-LOCKING NUT	ECROU DE SURETE	SICHERUNGSMUTTER
32B.02.010	MT-SU5141	1	SUPPORTO VIBRATORE SUPERIORE	VIBRATOR SUPPORT	SUPPORT VIBRATEUR SUP	STUETZE
32B.02.011	MT-VE263	2	VITE ESAGONALE M8x30 UNI 5737/77	HEXAGONAL-HEADED BOLT	VIS	SECHSECKIGE SCHRAUBE
32B.02.012	MT-MO5002	1	MOTORE SCUOTIFILTRO 36V	SHAKING FILTER ENGINE	MOTEUR SECOUE-FILTRE	SCHUETTelfILTERSMOTOR
32B.02.013	MT-GR5045	2	GOMMA ANTIURTO PER FILTRO	*****	*****	*****
32B.02.014	MT-GR5043	1	GOMMA FISSAGGIO ATTACCO SCUOTIFILTRO	*****	*****	*****
32B.02.015	MT-GR5044	1	GOMMA FISSAGGIO MOTORE SCUOTIFILTRO	GASKET	GARNITURE	DICHTUNG
32B.02.016	MT-MI5064	2	PIEDINO IN GOMMA	RUBBER FOOT	PIED EN CAOUTCHOUC	GUMMIFUSS
32B.02.017	MT-DD254	2	DADO AUTOBLOCCANTE M8	SELF-LOCKING NUT	ECROU DE SURETE	SICHERUNGSMUTTER

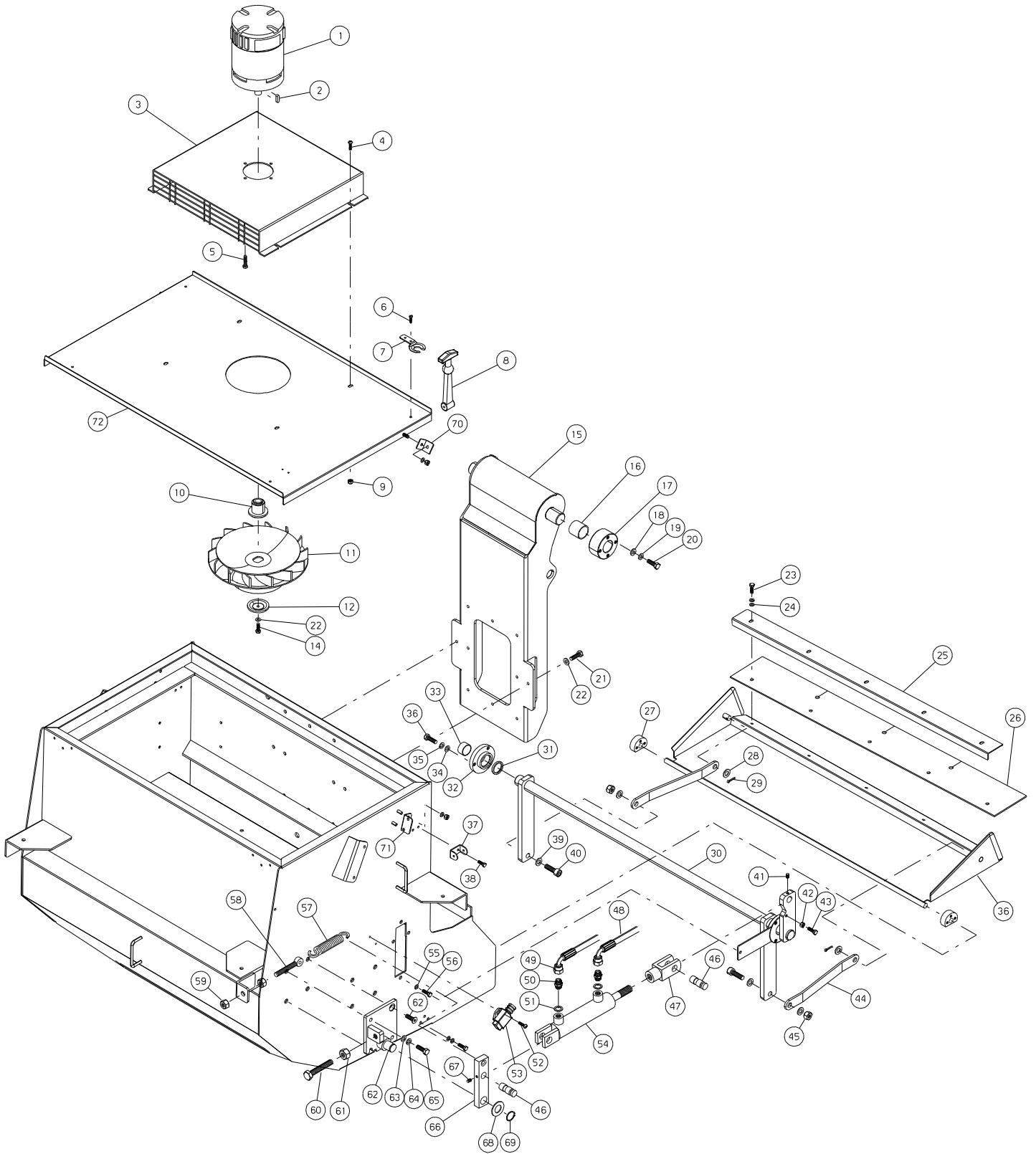

N.Position	Code Num	Qta	Descrizione	Description	Description	Bezeichnung
32B.03.001	MT-MO5038	1	MOTORE VENTOLA ASPIRAZIONE 36V	SUCTION FAN ENGINE 36	MOTEUR DU ROTOR	SAUGGEBLAESEMOTOR
32B.03.002	MT-CH009	1	CHIAVETTA 5X8X20	KEY	CLAVETTE	PASSFEDER (5x8x20)
32B.03.003	MT-SU5200	1	SUPPORTO MOTORE VENTOLA ASPIRAZIONE	*****	*****	*****
32B.03.004	MT-VV5004	4	VITE TESTA BOMBATA M6x20	CUP-HEADED BOLT	VIS BOMBEE	HALBRUNDSCHRAUBE
32B.03.005	MT-VE244	4	VITE ESAGONALE M6x20 UNI 5737/77	HEXAGONAL-HEADED BOLT	VIS	SECHSECKIGE SCHRAUBE
32B.03.006	MT-VV5003	2	VITE TESTA BOMBATA M4x10	CUP-HEADED BOLT	VIS	HALBRUNDSCHRAUBE
32B.03.007	MT-PT5154	1	PIASTRINA ANCORAGGIO GANCIO COFANO	*****	*****	*****
32B.03.008	MT-MI5052	2	GANCIO COFANO	*****	*****	*****
32B.03.009	MT-DD253	4	DADO AUTOBLOCCANTE M6	SELF-LOCKING NUT	ECROU DE SURETE	SICHERUNGSMUTTER
32B.03.010	MT-PE5071	1	PERNO VENTOLA DI ASPIRAZIONE	SUCTION FAN PIN	PIVOT DU ROTOR	BOLZEN
32B.03.011	MT-FU009	1	VENTOLA ASPIRAZIONE	SUCTION FAN	ROTOR	SAUGGEBLAESE
32B.03.012	MT-MV5042	1	RONDELLA PER PERNO VENTOLA	WASHER	RONDELLE PIVOT	SCHEIBE
32B.03.013	MT-RO254	1	RONDELLA SPACCATI DIAM. 6 UNI 1751	WASHER	RONDELLE	SCHEIBE
32B.03.014	MT-VE246	1	VITE ESAGONALE M6x30 UNI 5737/77	SCREW	VIS	SCHRAUBE
32B.03.015	MT-LV5092	1	BRACCIO SOLLEVAMENTO CASSONE S32	*****	*****	*****
32B.03.016	MT-BO5003	2	BOCCOLA AUTOLUBRIFICANTE 3030 KU	BUSH	DOUILLE	BUCHSE
32B.03.017	MT-SU5007	2	SUPPORTO PERNO CASSONE	BODY PIN SUPPORT	SUPP. PIVOT CAISSON	BOLZENSTUETZE
32B.03.018	MT-RO205	8	RONDELLA NORMALE DIAM. 10 UNI 6592/	WASHER	RONDELLE	SCHEIBE
32B.03.019	MT-RO256	8	RONDELLA SPACCATI DIAM.10 UNI 1751	WASHER	RONDELLE	SCHEIBE
32B.03.020	MT-VE282	8	VITE ESAGONALE M10x30 UNI 5737/77	HEXAGONAL-HEADED BOLT	VIS	SECHSECKIGE SCHRAUBE
32B.03.021	MT-VE260	8	VITE ESAGONALE M8x16 UNI 5737/77	HEXAGONAL-HEADED BOLT	VIS	SECHSECKIGE SCHRAUBE
32B.03.022	MT-RO203	8	RONDELLA NORMALE DIAM. 6 UNI 6592/6	WASHER D6	RONDELLE	SCHEIBE
32B.03.023	MT-VE243	5	VITE ESAGONALE M6x16 UNI 5737/77	HEXAGONAL-HEADED BOLT	VIS	SECHSECKIGE SCHRAUBE
32B.03.024	MT-RO403	5	RONDELLA NORM.DIAM. 6 UNI 6592/69 I	WASHER	RONDELLE	SCHEIBE
32B.03.025	MT-LM5219	1	LISTELLO GOMMA FLAP S32	*****	*****	*****
32B.03.026	MT-BP5054	1	GOMMA FLAP S32	*****	*****	*****
32B.03.027	MT-SU5006	2	SUPPORTO FLAP CHIUSURA	CLOSURE FLAP SUPPORT	SUPP. FLAP FERMETURE	STUETZE
32B.03.028	MT-RO5008	2	RONDELLA SLARG. D. 10x20 UNI6592/69	WASHER 10X20	RONDELLE 10X20	SCHEIBE
32B.03.029	MT-CP211	2	COPIGLIA DIAM.3x30 UNI 1336	SPLIT PIN	GOUPILLE 3X30	SPLINT
32B.03.030	MT-PE5083	1	PERNO ROTAZIONE FLAP S32	*****	*****	*****
32B.03.031	MT-GI5002	1	PARAPOLVERE IN PLASTICA D=32-d=25-S	PLASTIC DUST COVER	ANTI-POUSSIERE PLASTI	STAUBKAPPE
32B.03.032	MT-SU5004	1	SUPPORTO ALBERO FLAP DX	FLAP SHAFT SUPPORT	SUPPORT ARBRE	STUETZE
32B.03.033	MT-BO5004	1	BOCCOLA AUTOLUBRIFICANTE 2515 KU	BUSH	DOUILLE	SELBSTSCHMIERENDE BUC
32B.03.034	MT-RO204	6	RONDELLA PIANA M8	WASHER	RONDELLE	SCHEIBE
32B.03.035	MT-RO255	6	RONDELLA SPACCATI DIAM. 8 UNI 1751	WASHER	RONDELLE	SCHEIBE
32B.03.036	MT-TP5077	1	TELAIO FLAP S32	*****	*****	*****
32B.03.036	MT-VE262	6	VITE ESAGONALE M8x25 UNI 5137/77	SCREW	VIS	SECHSECKIGE SCHRAUBE
32B.03.037	MT-PT5103	2	PIASTRINA DI ATTACCO GANCIO COFANO	*****	*****	*****
32B.03.039	MT-RO218	2	RONDELLA NORMALE DIAM. 12 UNI 6592/	WASHER	RONDELLE NORM. 12	SCHEIBE
32B.03.040	MT-VB250	2	VITE CIL. BRUGOLA M12x35 UNI 5931	CHEESE BOLT	VIS	ZYLINDERSCHRAUBE
32B.03.041	MT-VG021	1	GRANO M6x10 UNI 5927/67	DOWEL	GRAIN	DUEBEL
32B.03.042	MT-DD205	1	DADO M8 UNI 5588/65	NUT	ECROU	MUTTER
32B.03.043	MT-VE267	1	VITE ESAGONALE M8x50 UNI 5737/77	SCREW	VIS	SCHRAUBE
32B.03.044	MT-LV5093	2	LEVA CHIUSURA FLAP S32	*****	*****	*****
32B.03.045	MT-DD207	2	DADO M12 UNI 5588/65	NUT	ECROU	MUTTER
32B.03.046	MT-PE5003	2	PERNO PER PISTONE FLAP	PIN	PIVOT	BOLZEN
32B.03.047	MT-MI5072	1	FORCELLA M16	FORK M16	FOURCHETTE M16	GABEL
32B.03.048	MT-TU5170	1	TUBO 1/4 F90-FD L=2400	*****	*****	*****
32B.03.049	MT-TU5184	1	TUBO 1/4 F90-FD L=2530	*****	*****	*****
32B.03.050	MT-MI033	2	NIPLES M-M G3/8 G3/8	NIPPLE	NIPLES	NIPPEL
32B.03.051	MT-RO5010	2	RONDELLA IN RAME 3/8	COPPER WASHER	RONDELLE EN CUIVRE	KOPFERSCHEIBE
32B.03.052	MT-VV5003	2	VITE TESTA BOMBATA M4x10	CUP-HEADED BOLT	VIS	HALBRUNDSCHRAUBE
32B.03.053	MT-IN5005	1	MICRO COMANDO SPIA FLAP	MICRO	MICRO	MIKROSCHALTER
32B.03.054	MT-MA5019	1	MARTINETTO IDRAULICO FLAP UBF34	HYDRAULIC JACK	CRIC HYDRAULIQUE	HEBEBOCK
32B.03.055	MT-RO301	1	RONDELLA SLARGATA.6x18 UNI 6592/69	WASHER	RONDELLE	SCHEIBE
32B.03.056	MT-VV5004	1	VITE TESTA BOMBATA M6x20	CUP-HEADED BOLT	VIS BOMBEE	HALBRUNDSCHRAUBE
32B.03.057	MT-ML5009	1	MOLLA FLAP	FLAP SPRING	RESSORT FLAP	KLAPPESFEDER
32B.03.058	MT-MI5080	1	TIRANTE AD OCCHIO M10X80 ZINCATO	TIE ROD M10X80	TIRANT A OEIL	SPANNSTANGE
32B.03.059	MT-DD206	2	DADO M10 UNI 5588/65	NUT	ECROU	MUTTER
32B.03.060	MT-VE306	1	VITE ESAGONALE M12X60 UNI5737/77	HEXAGONAL SCREW	VIS	SECHSECKIGE SCHRAUBE
32B.03.061	MT-DD207	1	DADO M12 UNI 5588/65	NUT	ECROU	MUTTER
32B.03.062	MT-PT5074	1	PIASTRA ATTACCO MARTINETTO FLAP	*****	*****	*****
32B.03.063	MT-RO204	4	RONDELLA PIANA M8	WASHER	RONDELLE	SCHEIBE
32B.03.064	MT-RO255	4	RONDELLA SPACCATI DIAM. 8 UNI 1751	WASHER	RONDELLE	SCHEIBE
32B.03.065	MT-VE262	4	VITE ESAGONALE M8x25 UNI 5137/77	SCREW	VIS	SECHSECKIGE SCHRAUBE
32B.03.066	MT-LV5006	1	LEVA PER PISTONE FLAP	LEVER	LEVIER	HEBEL
32B.03.067	MT-VG021	1	GRANO M6x10 UNI 5927/67	DOWEL	GRAIN	DUEBEL
32B.03.068	MT-RO209	1	RONDELLA NORMALE DIAM. 20 UNI 6592/	WASHER	RONDELLE	SCHEIBE
32B.03.069	MT-SG016	1	ANELLO SEEGER PER EST.DIAM.20 UNI	RING	SEEGER	SEEGERRING
32B.03.070	MT-PT5102	2	PIASTRINA FERMO PER COFANO IN RESIN	*****	*****	*****
32B.03.071	MT-PT5104	2	PIASTRINO ARRESTO CAVI COFANO	*****	*****	*****
32B.03.072	MT-CO5041	1	COPERCHIO CASSONE S32	*****	*****	*****

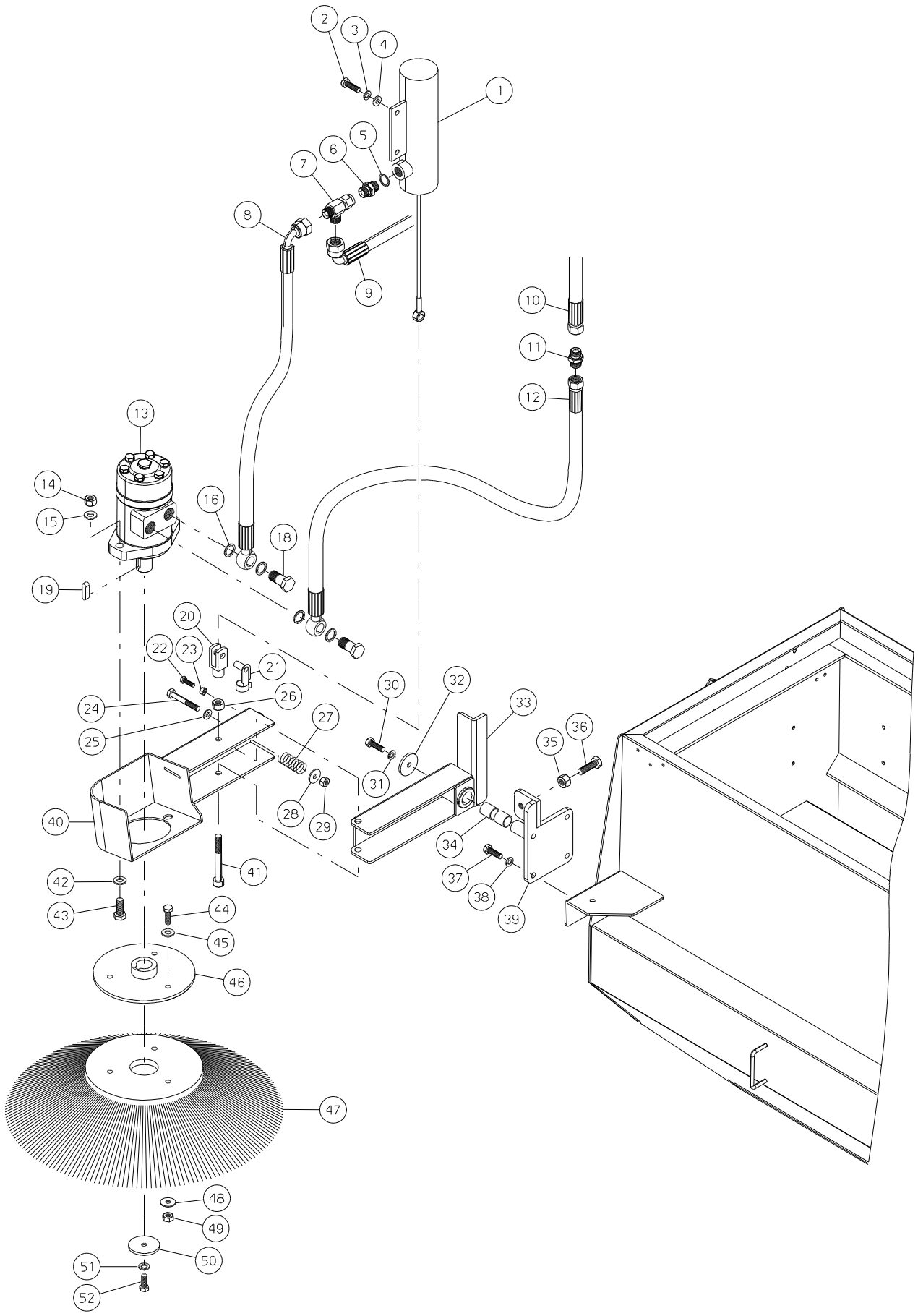

N.Position	Code Num	Qta	Descrizione	Description	Description	Bezeichnung
32B.04.001	MT-MA5021	1	MARTINETTO SPAZZ. LATERALE UBF34	SIDE BRUSH JACK	CRIC BROSSE LAT.	HEBEBOCK
32B.04.002	MT-VE260	2	VITE ESAGONALE M8x16 UNI 5737/77	HEXAGONAL-HEADED BOLT	VIS	SECHSECKIGE SCHRAUBE
32B.04.003	MT-RO204	2	RONDELLA PIANA M8	WASHER	RONDELLE	SCHEIBE
32B.04.004	MT-RO255	2	RONDELLA SPACCATA DIAM. 8 UNI 1751	WASHER	RONDELLE	SCHEIBE
32B.04.005	MT-RO5010	1	RONDELLA IN RAME 3/8	COPPER WASHER	RONDELLE EN CUIVRE	KOPFERSCHIEBE
32B.04.006	MT-MI033	1	NIPLES M-M G3/8 G3/8	NIPPLE	NIPLES	NIPPEL
32B.04.007	MT-RC5022	1	NIPLES A T 3/8 M-M.90 F.GIR.	NIPPLE	ADAPTATEUR	NIPPEL
32B.04.008	MT-TU5178	1	TUBO 3/8 F45 3/8-O 1/2 L=560	*****	*****	*****
32B.04.009	MT-TU5179	1	TUBO 3/8 F45-F90 L=2710	*****	*****	*****
32B.04.010	MT-TU5176	1	TUBO 3/8 FD-F90 L=2840	*****	*****	*****
32B.04.011	MT-MI033	1	NIPLES M-M G3/8 G3/8	NIPPLE	NIPLES	NIPPEL
32B.04.012	MT-TU5177	1	TUBO 3/8 FD-0 1/2 L=560	*****	*****	*****
32B.04.013	MT-MO163	1	MOTORE SPAZZOLA LATERALE	HYDRAULIC ENGINE	MOTEUR HYDR. BROSSE	HYDROMOTOR
32B.04.014	MT-DD207	2	DADO M12 UNI 5588/65	NUT	ECROU	MUTTER
32B.04.015	MT-RO218	2	RONDELLA NORMALE DIAM. 12 UNI 6592/	WASHER	RONDELLE NORM. 12	SCHEIBE
32B.04.016	MT-RO5002	6	RONDELLA RAME 1/2	COPPER WASHER	RONDELLE CUIVRE	KOPFERSCHIEBE
32B.04.018	MT-RC5014	2	VITE FORATA 1/2	SCREW	VIS	SCHRAUBE
32B.04.019	MT-CH045	1	LINGUETTA 8x7x30 UNI 6604-A	TONGUE	CLAVETTE	PASSFEDER
32B.04.020	MT-SN004	1	SNODO (forcella) M10	JOINT	JOINT	GELENK
32B.04.021	MT-MI009	1	CLIPS PER FORCELLA M10	PIN	PIVOT	GABELSBOLZEN
32B.04.022	MT-VE261	1	VITE TE M8x20	SCREW	VIS	SCHRAUBE
32B.04.023	MT-DD205	1	DADO M8 UNI 5588/65	NUT	ECROU	MUTTER
32B.04.024	MT-VE285	1	VITE ESAGONALE M10x65 UNI 5737/77	HEXAGONAL-HEADED BOLT	VIS M10x65	SECHSECKIGE SCHRAUBE
32B.04.025	MT-RO205	1	RONDELLA NORMALE DIAM. 10 UNI 6592/	WASHER	RONDELLE	SCHEIBE
32B.04.026	MT-DD206	1	DADO M10 UNI 5588/65	NUT	ECROU	MUTTER
32B.04.027	MT-ML5011	1	MOLLA SPAZZOLA LATERALE	SIDE BRUSH SPRING	RESSORT BROSSE LAT.	SEITENBUERSTESFEDER
32B.04.028	MT-MV5043	1	GUIDA MOLLA BRACCIO SPAZZOLA LATERA	SLIDE	GUIDE RESSORT BRAS BR	FUEHRUNG
32B.04.029	MT-DD255	1	DADO AUTOBLOCCANTE M10	SELF-LOCKING NUT	ECROU DE SURETE	SICHERUNGSMUTTER
32B.04.030	MT-VE262	1	VITE ESAGONALE M8x25 UNI 5137/77	SCREW	VIS	SECHSECKIGE SCHRAUBE
32B.04.031	MT-RO255	1	RONDELLA SPACCATA DIAM. 8 UNI 1751	WASHER	RONDELLE	SCHEIBE
32B.04.033	MT-LM5125	1	LAMIERA BRACCIO SPAZ.LATERALE DX	RIGHT SIDE BRUSH ARM	TOLE BRAS BROSSE LAT.	ARMSBLECH
32B.04.034	MT-BO5042	2	BOCCOLA NYLON	NYLON BUSH	COQUILLE	NYLONBUCHSE
32B.04.035	MT-DD206	1	DADO M10 UNI 5588/65	NUT	ECROU	MUTTER
32B.04.036	MT-VE291	1	VITE ESAGONALE M10X50 UNI 5737/77	HEXAGONAL-HEADED BOLT	VIS	SECHSECKIGE SCHRAUBE
32B.04.037	MT-VE262	4	VITE ESAGONALE M8x25 UNI 5137/77	SCREW	VIS	SECHSECKIGE SCHRAUBE
32B.04.038	MT-RO205	4	RONDELLA NORMALE DIAM. 10 UNI 6592/	WASHER	RONDELLE	SCHEIBE
32B.04.039	MT-SU5135	1	SUPPORTO SPAZZOLA LATERALE DESTRA	RIGHT BRUSH SUPPORT	*****	SEITENBUERSTESTUETZE
32B.04.040	MT-SU5137	1	SUPPORTO MOTORE SPAZZOLA LATERALE D	HYDRAULIK ENGINE SUPP	SUPPORT MOTEUR BROSSE	STUETZE
32B.04.041	MT-VE290	1	VITE ESAGONALE M10x90	HEXAGONAL-HEADED BOLT	VIS M10x90	SECHSECKIGE SCHRAUBE
32B.04.042	MT-RO218	2	RONDELLA NORMALE DIAM. 12 UNI 6592/	WASHER	RONDELLE NORM. 12	SCHEIBE
32B.04.043	MT-VE302	2	VITE ESAGONALE M12X35 UNI 5737/77	HEXAGONAL-HEADED BOLT	VIS M12X35	SECHSECKIGE SCHRAUBE
32B.04.044	MT-VE261	3	VITE TE M8x20	SCREW	VIS	SCHRAUBE
32B.04.045	MT-RO204	3	RONDELLA PIANA M8	WASHER	RONDELLE	SCHEIBE
32B.04.046	MT-FL5007	1	FLANGIA ATTACCO SPAZZOLA LATERALE	SIDE BRUSH FLANGE	FLANGE BROSSE LAT.	FLANSCH
32B.04.047	MT-SZ5000	1	SPAZZOLA LATERALE	SIDE NYLON BRUSH	BROSSE LATERALE NYLON	SEITENBUERSTE
32B.04.048	MT-RO302	3	RONDELLA SLARG.DIAM. 8x24 UNI 6592/	WASHER	RONDELLE	SCHEIBE
32B.04.049	MT-DD254	3	DADO AUTOBLOCCANTE M8	SELF-LOCKING NUT	ECROU DE SURETE	SICHERUNGSMUTTER
32B.04.050	MT-VI040	1	RONDELLA SPECIALE (ZINCATA)	WASHER	RONDELLE	SCHEIBE
32B.04.051	MT-RO255	1	RONDELLA SPACCATA DIAM. 8 UNI 1751	WASHER	RONDELLE	SCHEIBE
32B.04.052	MT-VE261	1	VITE TE M8x20	SCREW	VIS	SCHRAUBE

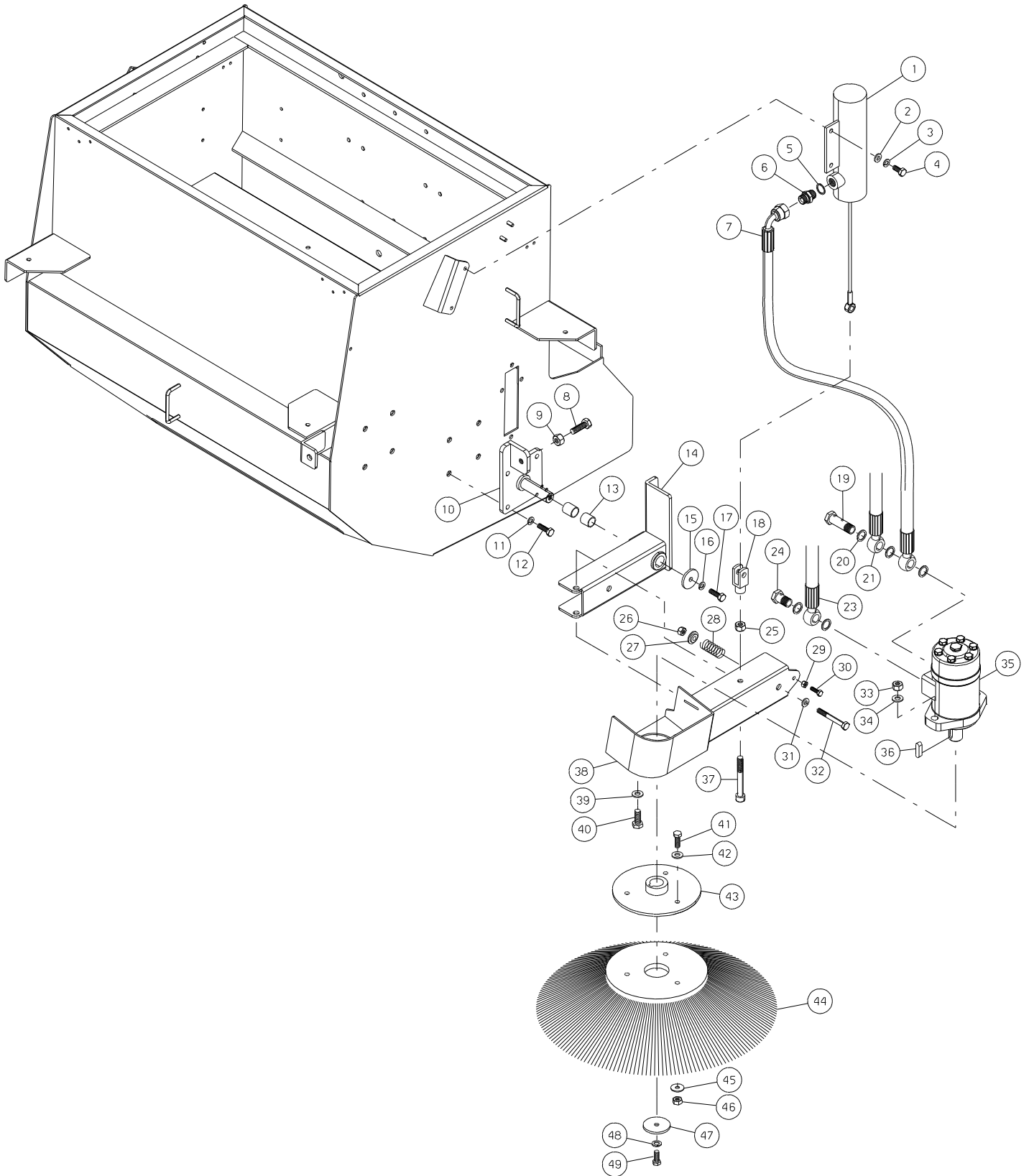

N.Position	Code Num	Qta	Descrizione	Description	Description	Bezeichnung
32B.05.001	MT-MA5021	1	MARTINETTO SPAZZ. LATERALE UBF34	SIDE BRUSH JACK	CRIC BROSSE LAT.	HEBEBOCK
32B.05.002	MT-RO255	2	RONDELLA SPACCATA DIAM. 8 UNI 1751	WASHER	RONDELLE	SCHEIBE
32B.05.003	MT-RO204	2	RONDELLA PIANA M8	WASHER	RONDELLE	SCHEIBE
32B.05.004	MT-VE260	2	VITE ESAGONALE M8x16 UNI 5737/77	HEXAGONAL-HEADED BOLT	VIS	SECHSECKIGE SCHRAUBE
32B.05.005	MT-RO5010	1	RONDELLA IN RAME 3/8	COPPER WASHER	RONDELLE EN CUIVRE	KOPFERSCHEIBE
32B.05.006	MT-MI033	1	NIPLES M-M G3/8 G3/8	NIPPLE	NIPLES	NIPPEL
32B.05.007	MT-TU5183	1	TUBO 1/4 F45 1/4- 0 1/2 L=560	*****	*****	*****
32B.05.008	MT-VE291	1	VITE ESAGONALE M10X50 UNI 5737/77	HEXAGONAL-HEADED BOLT	VIS	SECHSECKIGE SCHRAUBE
32B.05.009	MT-DD206	1	DADO M10 UNI 5588/65	NUT	ECROU	MUTTER
32B.05.010	MT-SU5139	1	SUPPORTO SPAZZOLA LATERALE SINISTRA	*****	*****	*****
32B.05.011	MT-RO205	4	RONDELLA NORMALE DIAM. 10 UNI 6592/	WASHER	RONDELLE	SCHEIBE
32B.05.012	MT-VE262	4	VITE ESAGONALE M8x25 UNI 5137/77	SCREW	VIS	SECHSECKIGE SCHRAUBE
32B.05.013	MT-BO5042	2	BOCCOLA NYLON	NYLON BUSH	COQUILLE	NYLONBUCHSE
32B.05.014	MT-LM5127	1	LAMIERA BRACCIO SPAZZ.LATERALE SINIS	LEFT SIDE BRUSH ARM P	TOLE BRAS BROSSE LAT.	ARMSBLECH
32B.05.015	MT-VI040	1	RONDELLA SPECIALE (ZINCATA)	WASHER	RONDELLE	SCHEIBE
32B.05.016	MT-RO255	1	RONDELLA SPACCATA DIAM. 8 UNI 1751	WASHER	RONDELLE	SCHEIBE
32B.05.017	MT-VE262	1	VITE ESAGONALE M8x25 UNI 5137/77	SCREW	VIS	SECHSECKIGE SCHRAUBE
32B.05.018	MT-SN004	1	SNODO (forcella) M10	JOINT	JOINT	GELENK
32B.05.019	MT-RC5079	1	VITE FORATA DOPPIA 1/2	SCREW	VIS PERCEE DOUBLE	SCHRAUBE
32B.05.020	MT-RO5002	5	RONDELLA RAME 1/2	COPPER WASHER	RONDELLE CUIVRE	KOPFERSCHEIBE
32B.05.021	MT-TU5181	1	TUBO 3/8 O 1/2- O 1/2 L=1000	*****	*****	*****
32B.05.023	MT-TU5182	1	TUBO 3/8 O 1/2-FD 3/8 L=1150	*****	*****	*****
32B.05.024	MT-RC5014	1	VITE FORATA 1/2	SCREW	VIS	SCHRAUBE
32B.05.025	MT-DD206	1	DADO M10 UNI 5588/65	NUT	ECROU	MUTTER
32B.05.026	MT-DD255	1	DADO AUTOBLOCCANTE M10	SELF-LOCKING NUT	ECROU DE SURETE	SICHERUNGSMUTTER
32B.05.027	MT-MV5043	1	GUIDA MOLLA BRACCIO SPAZZOLA LATERA	SLIDE	GUIDE RESSORT BRAS BR	FUEHRUNG
32B.05.028	MT-ML5011	1	MOLLA SPAZZOLA LATERALE	SIDE BRUSH SPRING	RESSORT BROSSE LAT.	SEITENBUERSTESFEDER
32B.05.029	MT-DD205	1	DADO M8 UNI 5588/65	NUT	ECROU	MUTTER
32B.05.030	MT-VE261	1	VITE TE M8x20	SCREW	VIS	SCHRAUBE
32B.05.031	MT-RO205	1	RONDELLA NORMALE DIAM. 10 UNI 6592/	WASHER	RONDELLE	SCHEIBE
32B.05.032	MT-VE285	1	VITE ESAGONALE M10x65 UNI 5737/77	HEXAGONAL-HEADED BOLT	VIS M10X65	SECHSECKIGE SCHRAUBE
32B.05.033	MT-DD207	2	DADO M12 UNI 5588/65	NUT	ECROU	MUTTER
32B.05.034	MT-RO218	2	RONDELLA NORMALE DIAM. 12 UNI 6592/	WASHER	RONDELLE NORM. 12	SCHEIBE
32B.05.035	MT-MO163	1	MOTORE SPAZZOLA LATERALE	HYDRAULIC ENGINE	MOTEUR HYDR. BROSSE	HYDROMOTOR
32B.05.036	MT-CH045	1	LINGUETTA 8x7x30 UNI 6604-A	TONGUE	CLAVETTE	PASSFEDER
32B.05.037	MT-VE290	1	VITE ESAGONALE M10x90	HEXAGONAL-HEADED BOLT	VIS M10X90	SECHSECKIGE SCHRAUBE
32B.05.038	MT-SU5140	1	SUPPORTO MOTORE SPAZZOLA SINISTRA	LEFT BRUSH ENGINE SUP	SUPPORT MOTEUR BROSSE	STUETZE
32B.05.039	MT-RO218	2	RONDELLA NORMALE DIAM. 12 UNI 6592/	WASHER	RONDELLE NORM. 12	SCHEIBE
32B.05.040	MT-VE302	2	VITE ESAGONALE M12X35 UNI 5737/77	HEXAGONAL-HEADED BOLT	VIS M12X35	SECHSECKIGE SCHRAUBE
32B.05.041	MT-VE261	3	VITE TE M8x20	SCREW	VIS	SCHRAUBE
32B.05.042	MT-RO204	3	RONDELLA PIANA M8	WASHER	RONDELLE	SCHEIBE
32B.05.043	MT-FL5007	1	FLANGIA ATTACCO SPAZZOLA LATERALE	SIDE BRUSH FLANGE	FLANGE BROSSE LAT.	FLANSCH
32B.05.044	MT-SZ5000	1	SPAZZOLA LATERALE	SIDE NYLON BRUSH	BROSSE LATERALE NYLON	SEITENBUERSTE
32B.05.045	MT-RO302	3	RONDELLA SLARG.DIAM. 8x24 UNI 6592/	WASHER	RONDELLE	SCHEIBE
32B.05.046	MT-DD254	3	DADO AUTOBLOCCANTE M8	SELF-LOCKING NUT	ECROU DE SURETE	SICHERUNGSMUTTER
32B.05.047	MT-VI040	1	RONDELLA SPECIALE (ZINCATA)	WASHER	RONDELLE	SCHEIBE
32B.05.048	MT-RO255	1	RONDELLA SPACCATA DIAM. 8 UNI 1751	WASHER	RONDELLE	SCHEIBE
32B.05.049	MT-VE261	1	VITE TE M8x20	SCREW	VIS	SCHRAUBE

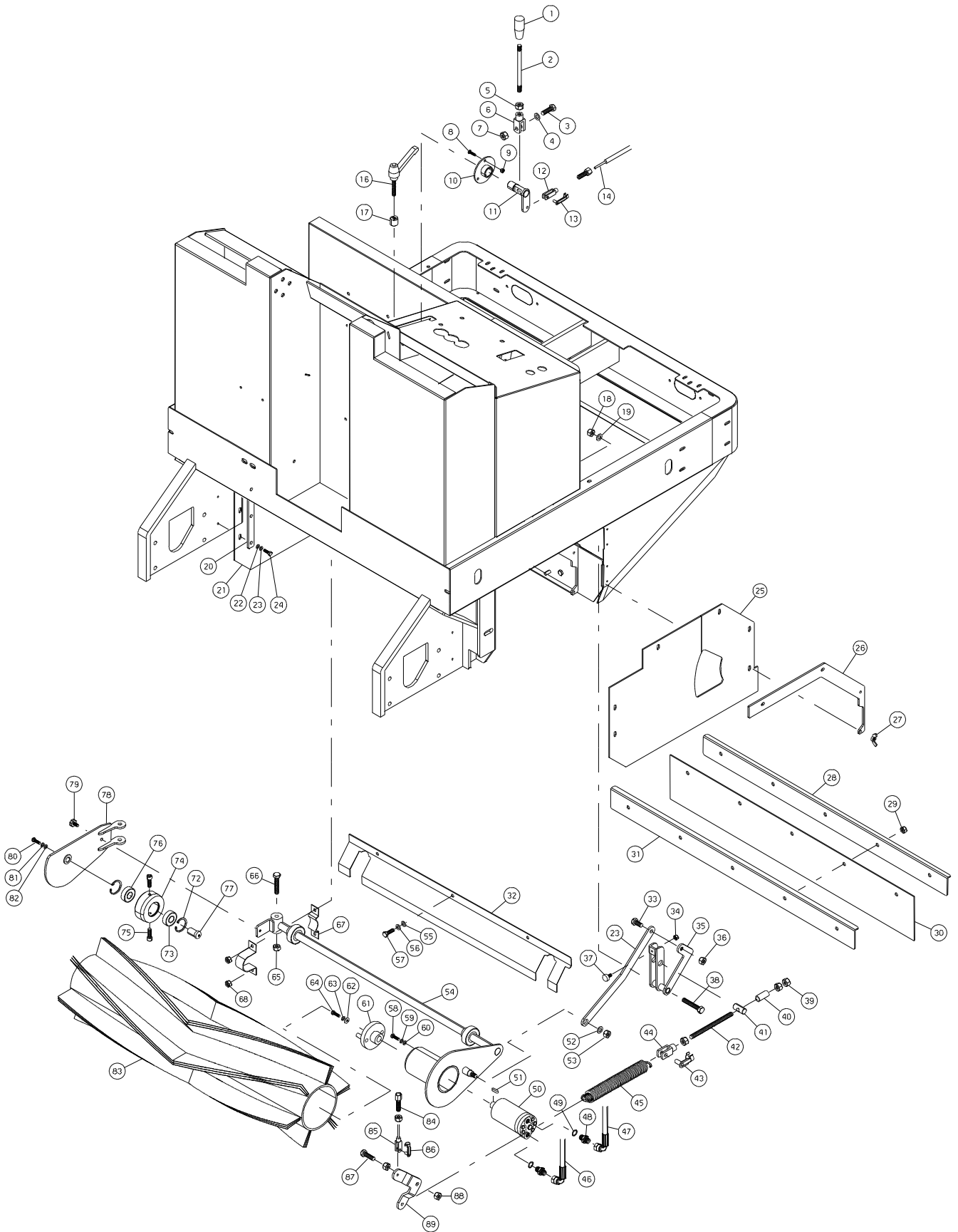

N.Position	Code Num	Qta	Descrizione	Description	Description	Bezeichnung
32B.06.001	MT-VP5002	1	POMELLO M10 CONICO	KNOB	POMMEAU	KUGELGRIFF
32B.06.002	MT-TI5029	1	ASTA COMANDO SPAZZOLA CENTR. S32	*****	*****	*****
32B.06.003	MT-VE282	1	VITE ESAGONALE M10x30 UNI 5737/77	HEXAGONAL-HEADED BOLT	VIS	SECHSECKIGE SCHRAUBE
32B.06.004	MT-RO205	1	RONDELLA NORMALE DIAM. 10 UNI 6592/	WASHER	RONDELLE	SCHEIBE
32B.06.005	MT-DD206	1	DADO M10 UNI 5588/65	NUT	ECROU	MUTTER
32B.06.006	MT-SN004	1	SNODO (forcella) M10	JOINT	JOINT	GELENK
32B.06.007	MT-DD206	1	DADO M10 UNI 5588/65	NUT	ECROU	MUTTER
32B.06.008	MT-VV5004	3	VITE TESTA BOMBATA M6x20	CUP-HEADED BOLT	VIS BOMBEE	HALBRUNDSCHRAUBE
32B.06.009	MT-DD204	3	DADO M6 UNI 5588/65	NUT	ECROU	MUTTER
32B.06.010	MT-FL5032	1	FLANGIA DI RINVIO S32	*****	*****	*****
32B.06.011	MT-LV5094	1	LEVA COMANDO SPAZZOLA CENTRALE S32	*****	*****	*****
32B.06.014	MT-MI5129	1	CAVO SOLLEVAMENTO SPAZ. CENTR. S32	*****	*****	*****
32B.06.016	MT-VP5012	1	POMELLO A LEVA M8x20 S32	*****	*****	*****
32B.06.017	MT-PE5087	1	PERNO ARRESTO DISCESA SPAZZOLA CENT	*****	*****	*****
32B.06.018	MT-DD255	1	DADO AUTOBLOCCANTE M10	SELF-LOCKING NUT	ECROU DE SURETE	SICHERUNGSMUTTER
32B.06.019	MT-RO205	1	RONDELLA NORMALE DIAM. 10 UNI 6592/	WASHER	RONDELLE	SCHEIBE
32B.06.020	MT-LM5007	2	LISTELLO LAT. INT.	BLADE	LISTEL	SEITENLEISTE
32B.06.021	MT-BP5052	1	GOMMA PARAPOLVERE DX SPAZZOLA CENTR	*****	*****	*****
32B.06.022	MT-RO203	6	RONDELLA NORMALE DIAM. 6 UNI 6592/6	WASHER D6	RONDELLE	SCHEIBE
32B.06.023	MT-LV5096	1	LEVA SOLLEVAMENTO SP. CENTRALE S32	*****	*****	*****
32B.06.023	MT-RO254	6	RONDELLA SPACCATA DIAM. 6 UNI 1751	WASHER	RONDELLE	SCHEIBE
32B.06.024	MT-VE244	6	VITE ESAGONALE M6x20 UNI 5737/77	HEXAGONAL-HEADED BOLT	VIS	SECHSECKIGE SCHRAUBE
32B.06.025	MT-BP5051	1	GOMMA PARAPOLVERE SX SPAZZOLA CENTR	*****	*****	*****
32B.06.026	MT-LM5226	2	LAMIERA MOBILE SPAZZOLA CENTRALE S3	*****	*****	*****
32B.06.027	MT-VL293	4	DADO AD ALETTE M6 UNI 5448/71	*****	*****	*****
32B.06.028	MT-LM5221	1	1 LISTELLO MINIGONNA POST. S32	*****	*****	*****
32B.06.029	MT-DD205	5	DADO M8 UNI 5588/65	NUT	ECROU	MUTTER
32B.06.030	MT-BP5053	1	GOMMA PARAPOLVERE POST. SPAZ. CENTR	*****	*****	*****
32B.06.031	MT-LM5222	1	2 LISTELLO MINIGONNA POST. S32	*****	*****	*****
32B.06.032	MT-LM5227	1	LAMIERA PROTEZIONE SPAZZOLA CENTRAL	*****	*****	*****
32B.06.033	MT-VE281	1	VITE ESAGONALE M10x20 UNI5737/77	HEXAGONAL-HEADED BOLT	VIS M10X20	SECHSECKIGE SCHRAUBE
32B.06.034	MT-DD204	1	DADO M6 UNI 5588/65	NUT	ECROU	MUTTER
32B.06.035	MT-LV5098	1	LEVA RINVIO COMANDO SP. CENTRALE S32	*****	*****	*****
32B.06.036	MT-DD255	1	DADO AUTOBLOCCANTE M10	SELF-LOCKING NUT	ECROU DE SURETE	SICHERUNGSMUTTER
32B.06.037	MT-MI2509	1	ANTIVIBRANTE 18x7,5 M6 (TAMPONE)	VIBRATION-DAMPING	ANTIVIBRATOIRE	ERSCHUTTERUNGSFREIER
32B.06.038	MT-VE5009	1	VITE ESAGONALE M10x80 UNI 5737/77	HEXAGONAL-HEADED BOLT	VIS M10X80	SECHSECKIGE SCHRAUBE
32B.06.039	MT-DD206	2	DADO M10 UNI 5588/65	NUT	ECROU	MUTTER
32B.06.040	MT-DT5041	1	DISTANZIALE VITE LEVA SPAZZOLA CENT	SPACER	ENTRETOISE LEVIER BRO	ABSTANDSTUECK
32B.06.041	MT-PE5064	1	PERNO LEVA SPAZZOLA CENTRALE	TIE ROD	PIVOT LEVIER BROsse C	BOLZEN
32B.06.042	MT-TI5030	1	TIRANTE SPAZZOLA CENTR. S32	*****	*****	*****
32B.06.043	MT-SN004	1	SNODO (forcella) M10	JOINT	JOINT	GELENK
32B.06.044	MT-MI009	1	CLIPS PER FORCELLA M10	PIN	PIVOT	GABELSBOLZEN
32B.06.045	MT-ML5010	1	MOLLA SPAZZOLA CENTRALE	CENTRAL BRUSH SPRING	RESSORT BROsse CENT.	ZENTRALBUERSTESFEDER
32B.06.046	MT-TU069	1	TUBO 3/8 F90 - F90 L=720	*****	*****	*****
32B.06.047	MT-TU066	1	TUBO FD - F90	*****	*****	*****
32B.06.048	MT-MI033	2	NIPLES M/M G3/8 - G3/8	NIPPLE	NIPPLES	NIPPEL
32B.06.049	MT-RO5010	2	RONDELLA IN RAME 3/8	COPPER WASHER	RONDELLE EN CUIVRE	KOPFERSCHEIBE
32B.06.050	MT-MO162	1	MOTORE SPAZZOLA CENTRALE	HYDRAULIC MOTOR	MOTEUR HYDR. BROsse	HYDROMOTOR
32B.06.051	MT-CH008	1	LINGUETTA 5x5x15 UNI6604-A	TONGUE	CLAVETTE	PASSFEDER
32B.06.052	MT-RO205	1	RONDELLA NORMALE DIAM. 10 UNI 6592/	WASHER	RONDELLE	SCHEIBE
32B.06.053	MT-DD255	1	DADO AUTOBLOCCANTE M10	SELF-LOCKING NUT	ECROU DE SURETE	SICHERUNGSMUTTER
32B.06.054	MT-PE5084	1	PERNO SPAZZOLA CENTRALE S32	*****	*****	*****
32B.06.055	MT-RO204	3	RONDELLA PIANA M8	WASHER	RONDELLE	SCHEIBE
32B.06.056	MT-RO255	3	RONDELLA SPACCATA DIAM. 8 UNI 1751	WASHER	RONDELLE	SCHEIBE
32B.06.057	MT-VE261	3	VITE TE M8x20	SCREW	VIS	SCHRAUBE
32B.06.058	MT-VE244	3	VITE ESAGONALE M6x20 UNI 5737/77	HEXAGONAL-HEADED BOLT	VIS	SECHSECKIGE SCHRAUBE
32B.06.059	MT-RO254	3	RONDELLA SPACCATA DIAM. 6 UNI 1751	WASHER	RONDELLE	SCHEIBE
32B.06.060	MT-RO203	3	RONDELLA NORMALE DIAM. 6 UNI 6592/6	WASHER D6	RONDELLE	SCHEIBE
32B.06.061	MT-FL5001	1	FLANGIA TRASCINAMENTO SPAZZOLA	BRUSH FLANGE	FLASQUE BROsse	FLANSCH
32B.06.062	MT-RO203	1	RONDELLA NORMALE DIAM. 6 UNI 6592/6	WASHER D6	RONDELLE	SCHEIBE
32B.06.063	MT-RO254	1	RONDELLA SPACCATA DIAM. 6 UNI 1751	WASHER	RONDELLE	SCHEIBE
32B.06.064	MT-VE244	1	VITE ESAGONALE M6x20 UNI 5737/77	HEXAGONAL-HEADED BOLT	VIS	SECHSECKIGE SCHRAUBE
32B.06.065	MT-DD255	1	DADO AUTOBLOCCANTE M10	SELF-LOCKING NUT	ECROU DE SURETE	SICHERUNGSMUTTER
32B.06.066	MT-VE288	1	VITE ESAGONALE M10x70 UNI 5737/77	HEXAGONAL-HEADED BOLT	VIS	SECHSECKIGE SCHRAUBE
32B.06.067	MT-CS052	2	CUSCINETTO C/SUPPORTO P47+YAR 204 F	BEARING WITH SUPPORT	COUSSINET AVEC SUPPOR	LAGER MIT STUETZE
32B.06.068	MT-DD254	4	DADO AUTOBLOCCANTE M8	SELF-LOCKING NUT	ECROU DE SURETE	SICHERUNGSMUTTER
32B.06.072	MT-SG016	2	ANELLO SEEGER PER EST. DIAM. 20 UNI	RING	SEEGER	SEEGERRING
32B.06.073	MT-CS027	2	CUSCINETTO SKF 6203 2RS1	BEARING	ROULEMENT	KUGELLAGER
32B.06.074	MT-FL5023	1	FLANGIA SUPPORTO SPAZZOLA CENTRALE	FLANGE	BRIDE SUPPORT BROsse	FLANSCH
32B.06.075	MT-VB229	2	VITE CIL. BRUGOLA M8x10 UNI 5931/77	CHEESE BOLT	VIS M8X10	ZYLINDERSCHRAUBE
32B.06.077	MT-SU567	1	SUPPORTO SPAZZOLA CENTRALE S34	*****	*****	*****
32B.06.078	MT-SU5202	1	SUPPORTO BRACCIO DX SPAZZOLA CENTR.	*****	*****	*****
32B.06.079	MT-VP5009	1	VOLANTINO M6x10	STEERING WHEEL	VOLANT A MAIN	LENKRAD

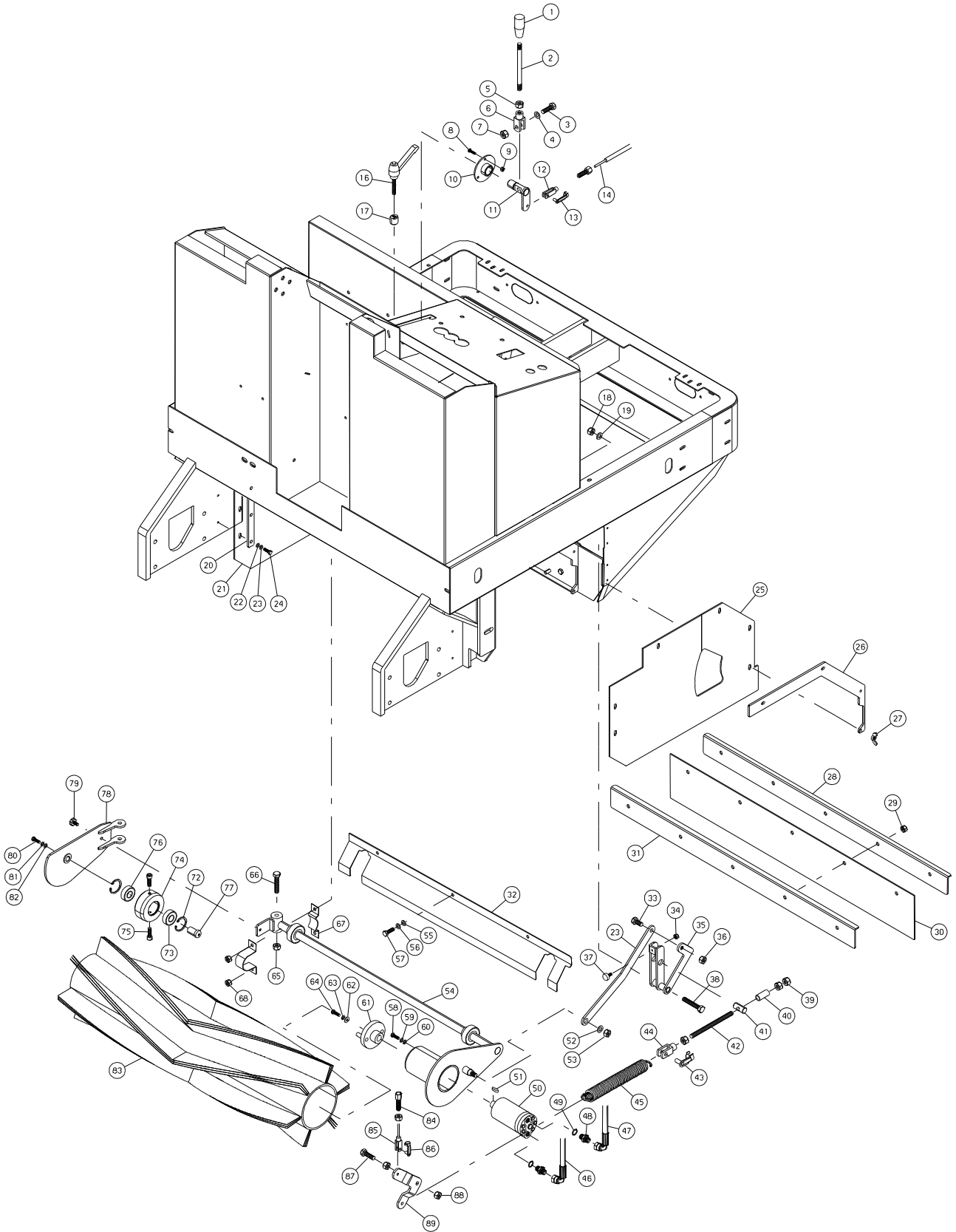



N.Position	Code Num	Qta	Descrizione	Description	Description	Bezeichnung
32B.06.080	MT-VE261	1	VITE TE M8x20	SCREW	VIS	SCHRAUBE
32B.06.081	MT-RO254	1	RONDELLA SPACCATA DIAM. 6 UNI 1751	WASHER	RONDELLE	SCHEIBE
32B.06.082	MT-RO203	1	RONDELLA NORMALE DIAM. 6 UNI 6592/6	WASHER D6	RONDELLE	SCHEIBE
32B.06.083	MT-SZ5009	1	SPAZZOLA CENTRALE S32	*****	*****	*****
32B.06.087	MT-VE263	1	VITE ESAGONALE M8x30 UNI 5737/77	HEXAGONAL-HEADED BOLT	VIS	SECHSECKIGE SCHRAUBE
32B.06.088	MT-DD206	2	DADO M10 UNI 5588/65	NUT	ECROU	MUTTER
32B.06.089	MT-LV5095	1	LEVA COMANDO SPAZZOLA CENTRALE S32	*****	*****	*****

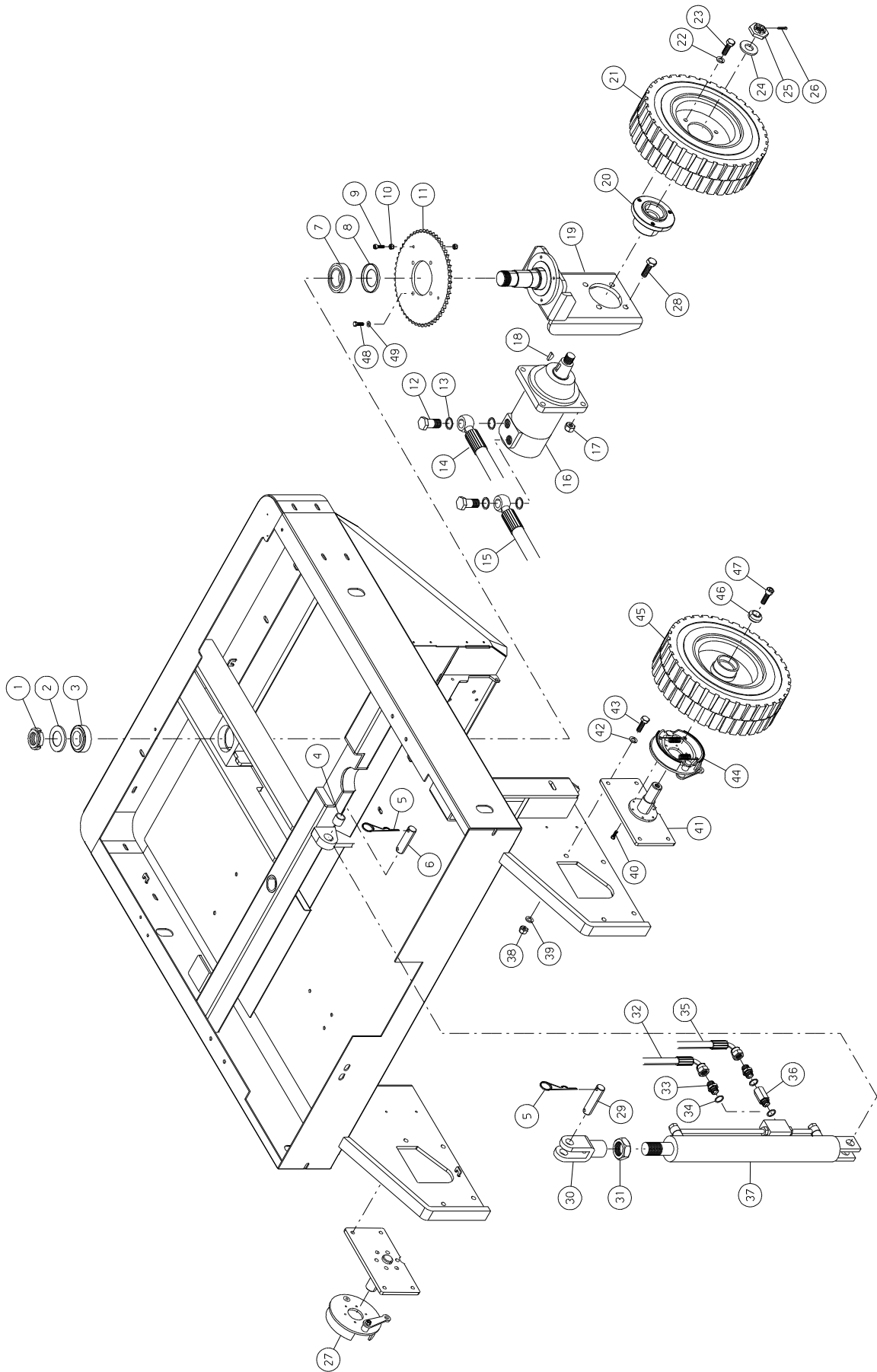

N.Position	Code Num	Qta	Descrizione	Description	Description	Bezeichnung
32B.07.001	MT-GH025	1	GHIERA M35X1.5	RING NUT	EMBOUT	GITTER
32B.07.002	MT-GI5001	1	PARAPOLVERE IN LAMIERA D=60-d=35 x	DUST COVER	ANTI-POUSSIERE	STAUBKAPPE
32B.07.003	MT-CS048	1	CUSCINETTO CONICO 32007 X/Q	BEARING	ROULEMENT	ROLLENLAGER
32B.07.004	MT-BO5042	1	BOCCOLA NYLON	NYLON BUSH	COQUILLE	NYLONBUCHSE
32B.07.005	MT-SP006	1	SPINA ELASTICA 4X22	PIN	CONNECTEUR 4X22	SPANNSTIFT
32B.07.006	MT-PE5072	1	PERNO CORTO MARTINETTO CASSONE	SHORT TIE ROD	PIVOT COURT CRIC CONT	KURZBOLZEN
32B.07.007	MT-CS036	1	CUSCINETTO 32008X/Q	BEARING 32008X	ROULEMENT	KUGELLAGER
32B.07.008	MT-GI5000	1	PARAPOLVERE IN LAMIERA D=66,5-d=40	ANTIDUST	ANTI-POUSSIERE	SAUBABDICHTUNG
32B.07.009	MT-VB231	2	VITE CIL. BRUGOLA M8x20 ZINCATA	CHEESE-HEADED SCREW	VIS	ZYLINDERSCHRAUBE
32B.07.010	MT-DD205	4	DADO M8 UNI 5588/65	NUT	ECROU	MUTTER
32B.07.011	MT-XD5006	1	CORONA STERZO	STEERING WHEEL CROWN	COURONNE BARRE DIRECT	KRANZ
32B.07.012	MT-RC5014	2	VITE FORATA 1/2	SCREW	VIS	SCHRAUBE
32B.07.013	MT-RO5002	4	RONDELLA RAME 1/2	COPPER WASHER	RONDELLE CUIVRE	KOPFERSCHIEBE
32B.07.014	MT-TU5056	1	TUBO 1/2 O 1/2 - O 1/2 L=1360	*****	*****	*****
32B.07.015	MT-TU5056	1	TUBO 1/2 O 1/2 - O 1/2 L=1360	*****	*****	*****
32B.07.016	MT-MO5051	1	MOTORE IDRAULICO TRAZIONE	TRACTION HYDRAULIC EN	MOTEUR HYDRAULIQUE TR	HYDROANTRIEBMOTOR
32B.07.017	MT-DD256	4	DADO AUTOBLOCCANTE M12	SELF-LOCKING NUT	ECROU DE SURETE M12	SICHERUNGSMUTTER
32B.07.018	MT-CH011	1	LINGUETTA 5x5x20 UNI6604-A	TONGUE	CLAVETTE	PASSFEDER
32B.07.019	MT-SU5199	1	SUPPORTO MOTORUOTA S32	*****	*****	*****
32B.07.020	MT-RP5027	1	MOZZO RUOTA POST. S32	*****	*****	*****
32B.07.021	MT-RT5026	1	RUOTA C/CERCHIO POSTERIORE S32	*****	*****	*****
32B.07.022	MT-RO256	3	RONDELLA SPACCATA DIAM.10 UNI 1751	WASHER	RONDELLE	SCHEIBE
32B.07.023	MT-VE289	3	VITE ESAGONALE M10X25 UNI 5737/77 Z	HEXAGONAL-HEADED BOLT	VIS	SECHSECKIGE SCHRAUBE
32B.07.024	MT-RO5018	1	RONDELLA SLARGATA DIAM 20x45	WASHER	RONDELLE 20X45	SCHEIBE
32B.07.025	MT-DD5019	1	DADO AD INTAGLI BASSO M20x1.5 UNI 5	*****	*****	*****
32B.07.026	MT-CP213	1	COPPIGLIA 3x60 ZINC.	SPLIT PIN	GOUPILLE	SPLINT
32B.07.027	MT-FN028	1	MASSA FRENANTE DX S32	*****	*****	*****
32B.07.028	MT-VE303	4	VITE ESAGONALE M12X40 UNI 5737/77	*****	*****	*****
32B.07.029	MT-PE5072	1	PERNO CORTO MARTINETTO CASSONE	SHORT TIE ROD	PIVOT COURT CRIC CONT	KURZBOLZEN
32B.07.030	MT-FR5006	1	FORCELLA X MARTINETTO CASSONE	FORK	FOURCHETTE X CRIC CON	GABEL
32B.07.031	MT-DD5017	1	DADO M20x1,5 BASSO	*****	*****	*****
32B.07.032	MT-TU5080	1	TUBO 1/4 F90 F90 260^ L=280	PIPE	TUYAU 1/4 F90	ROHR
32B.07.033	MT-RC5057	2	NIPPLO M1/4 M1/4 CON FORO USCITA 1m	NIPPLE	NIPPLES M1/4	NIPPEL
32B.07.034	MT-RO5901	3	RONDELLA IN RAME 1/4"	COPPER WASHER	RONDELLE	KOPFERSCHRAUBE
32B.07.035	MT-TU5079	1	TUBO 1/4 F90 F90 180^ L=450	PIPE	TUYAU 1/4 180^	ROHR
32B.07.036	MT-RC5059	1	RACCORDO COLONNETTA CORTA M1/4 F1/4	SHORT PIPE FITTING	RACCORD COLONNETTE CO	ANSCHLUSS
32B.07.037	MT-MA5024	1	MARTINETTO SOLLEVAMENTO CASSONE S32	*****	*****	*****
32B.07.038	MT-DD255	4	DADO AUTOBLOCCANTE M10	SELF-LOCKING NUT	ECROU DE SURETE	SICHERUNGSMUTTER
32B.07.039	MT-RO205	4	RONDELLA NORMALE DIAM. 10 UNI 6592/	WASHER	RONDELLE	SCHEIBE
32B.07.040	MT-VB5003	12	VITE CILINDRICA BRUGOLA M5x16	*****	*****	*****
32B.07.041	MT-RP5024	2	MOZZO RUOTA S32	*****	*****	*****
32B.07.042	MT-RO205	4	RONDELLA NORMALE DIAM. 10 UNI 6592/	WASHER	RONDELLE	SCHEIBE
32B.07.043	MT-VE282	4	VITE ESAGONALE M10x30 UNI 5737/77	HEXAGONAL-HEADED BOLT	VIS	SECHSECKIGE SCHRAUBE
32B.07.044	MT-FN029	1	MASSA FRENANTE SX S32	*****	*****	*****
32B.07.045	MT-RT5027	2	RUOTA C/CERCHIO ANTERIORE S32	*****	*****	*****
32B.07.046	MT-RO5024	2	RONDELLA FISSAGGIO RUOTE ANTERIORI	*****	*****	*****
32B.07.047	MT-VB248	2	VITE CIL. BRUGOLA M12x25 UNI 5931	*****	*****	*****
32B.07.048	MT-VE260	4	VITE ESAGONALE M8x16 UNI 5737/77	HEXAGONAL-HEADED BOLT	VIS	SECHSECKIGE SCHRAUBE
32B.07.049	MT-RO255	4	RONDELLA SPACCATA DIAM. 8 UNI 1751	WASHER	RONDELLE	SCHEIBE

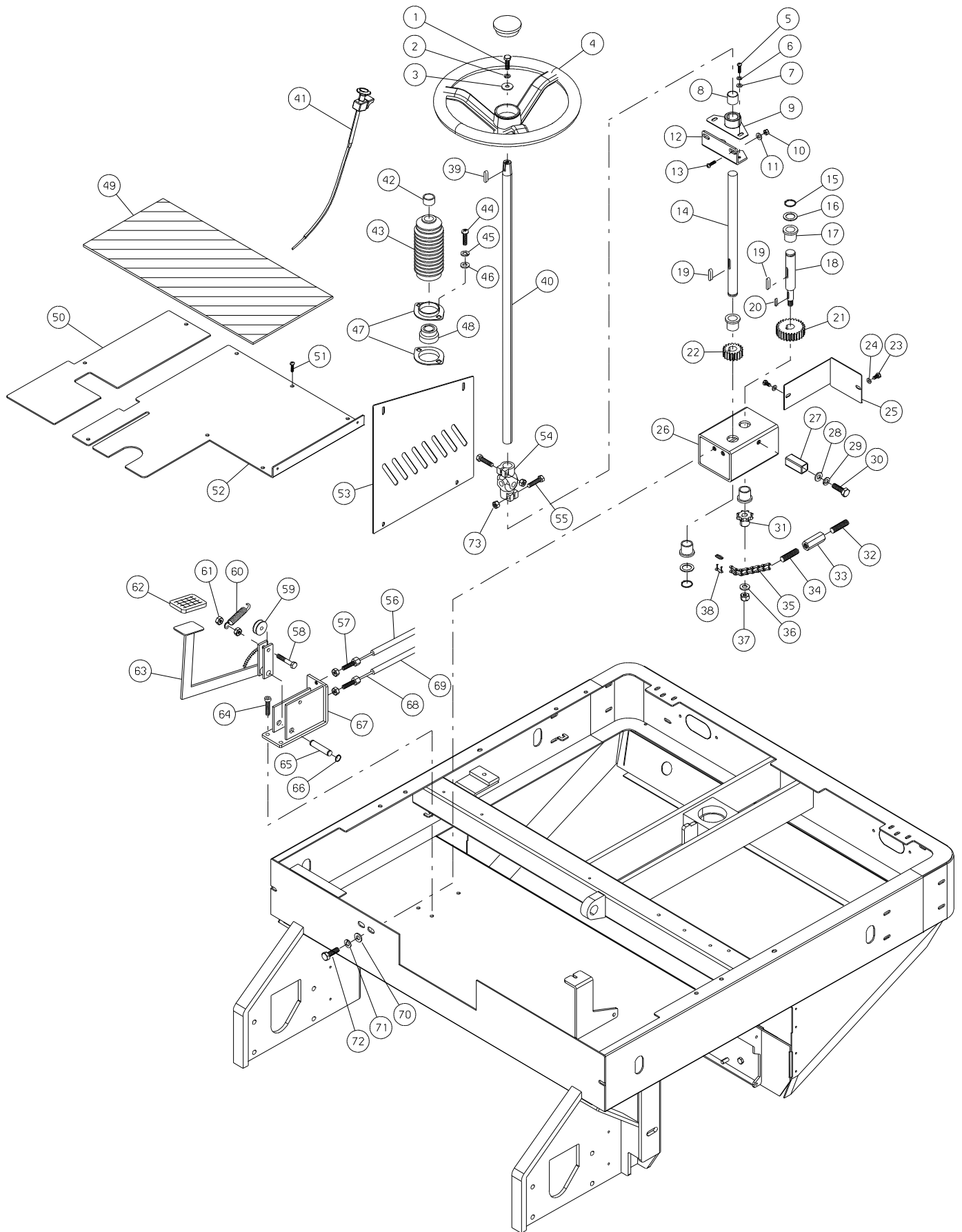

N.Position	Code Num	Qta	Descrizione	Description	Description	Bezeichnung
32B.08.001	MT-VE261	1	VITE TE M8x20	SCREW	VIS	SCHRAUBE
32B.08.002	MT-RO255	1	RONDELLA SPACCATA DIAM. 8 UNI 1751	WASHER	RONDELLE	SCHEIBE
32B.08.003	MT-RO302	1	RONDELLA SLARG.DIAM. 8x24 UNI 6592/	WASHER	RONDELLE	SCHEIBE
32B.08.004	MT-MI5049	1	VOLANTE CON TAPPO	STEERING WHEEL	VOLANT AVEC BOUCHON	LENKRAD MIT STOPFEN
32B.08.005	MT-VE244	2	VITE ESAGONALE M6x20 UNI 5737/77	HEXAGONAL-HEADED BOLT	VIS	SECHSECKIGE SCHRAUBE
32B.08.006	MT-RO254	2	RONDELLA SPACCATA DIAM. 6 UNI 1751	WASHER	RONDELLE	SCHEIBE
32B.08.007	MT-RO305	2	RONDELLA SLARGATA DIAM. 6x24 UNI 65	WASHER	RONDELLE	SCHEIBE
32B.08.008	MT-BO5042	1	BOCCOLA NYLON	NYLON BUSH	COQUILLE	NYLONBUCHSE
32B.08.009	MT-SU5151	1	SUPPORTO ALBERO STERZO	SHAFT SUPPORT	SUPPORT BARRE DE DIRE	LENKWELLESTUETZE
32B.08.010	MT-DD253	2	DADO AUTOBLOCCANTE M6	SELF-LOCKING NUT	ECROU DE SURETE	SICHERUNGSMUTTER
32B.08.011	MT-RO305	2	RONDELLA SLARGATA DIAM. 6x24 UNI 65	WASHER	RONDELLE	SCHEIBE
32B.08.012	MT-PT5093	1	PIASTRA SUPPORTO ALBERO STERZO	SUPPORT PLATE	PLAQUE SUPPORT BARRE	PLATTE
32B.08.013	MT-VV5004	2	VITE TESTA BOMBATA M6x20	CUP-HEADED BOLT	VIS BOMBEE	HALBRUNDSCHRAUBE
32B.08.014	MT-PE5074	1	PERNO SCATOLA STERZO	STEERING BOX PIN	PIVOT CARTER DU VOLAN	BOLZEN
32B.08.015	MT-SG009	2	ANELLO SEEGER PER EST. D.17 UNI 74	RING	BAGUE SEEGER	SEEGERRING
32B.08.016	MT-RO5016	2	SPESSORE PER AGGIUSTAMENTO De=21 Sp	DISTANCE WASHER	EPAISSEUR DE REGLAGE	ABSTANDSCHEIBE
32B.08.017	MT-BO5044	1	BOCCOLA SINTERIZZATA	BUSH	COQUILLE FRITTEE	SCHEIBE
32B.08.018	MT-AL5038	1	ALBERO PIGNONE	PINION SHAFT	TIRANT DU PIGNON	RIETZELWELLE
32B.08.019	MT-CH023	2	LINGUETTA 6x6x30 UNI6604-A	TONGUE	CLAVETTE 6X6X30	PASSFEDER
32B.08.020	MT-CH020	1	LINGUETTA 6x6x25 UNI6604-A	TONGUE	CLAVETTE 6X6X25	PASSFEDER
32B.08.021	MT-IG5002	1	INGRANAGGIO STERZO Z=13	GEAR	COURONNE Z=13	LENKGETRIEBE
32B.08.022	MT-IG5001	1	INGRANAGGIO STERZO Z=26	GEAR	COURONNE Z=26	LENKGETRIEBE
32B.08.023	MT-VE241	2	VITE ESAGONALE M6x10 UNI 5737/77	HEXAGONAL SCREW	VIS	SECHSECKIGE SCHRAUBE
32B.08.024	MT-RO254	2	RONDELLA SPACCATA DIAM. 6 UNI 1751	WASHER	RONDELLE	SCHEIBE
32B.08.025	MT-PT5073	1	PIASTRA COPERCHIO SCATOLA STERZO	PLATE	*****	PLATTE
32B.08.026	MT-MV5048	1	SCATOLA STERZO	STEERING BOX	BOITE DE DIRECTION	LENKGEHAEUSE
32B.08.027	MT-DT5066	1	DISTANZIALE SCATOLA STERZO S32	*****	*****	*****
32B.08.028	MT-RO205	1	RONDELLA NORMALE DIAM. 10 UNI 6592/	WASHER	RONDELLE	SCHEIBE
32B.08.029	MT-RO256	1	RONDELLA SPACCATA DIAM.10 UNI 1751	WASHER	RONDELLE	SCHEIBE
32B.08.030	MT-VE285	1	VITE ESAGONALE M10x65 UNI 5737/77	HEXAGONAL-HEADED BOLT	VIS M10X65	SECHSECKIGE SCHRAUBE
32B.08.031	MT-XD5005	1	PIGNONE STERZO	STEERING PINION	PIGNON BARRE DE DIREC	LENKRIETZEL
32B.08.032	MT-MV5039	1	VITE TENDICATENA SINISTRA	LEFT SCREW	VIS TENDEUSE DE CHAIN	KETTENSPIANNERSCHRAUBE
32B.08.033	MT-MV5040	1	TENDICATENA	CHAIN TIGHTENER	TENDEUR DE CHAINE	KETTENSPIANNER
32B.08.034	MT-MV5041	1	VITE TENDICATENA DESTRA	LEFT SCREW	VIS TENDEUSE DE CHAIN	KETTENSPIANNERSCHRAUBE
32B.08.035	MT-CT5013	1	CATENA STERZO S32 1/2" 141 PASSI	*****	*****	*****
32B.08.036	MT-RO257	1	RONDELLA SPACCATA D.12 UNI 1751	WASHER	RONDELLE	SCHEIBE
32B.08.037	MT-DD256	1	DADO AUTOBLOCCANTE M12	SELF-LOCKING NUT	ECROU DE SURETE M12	SICHERUNGSMUTTER
32B.08.038	MT-CT5010	2	GIUNTO 1/2-5/16	JOINT	JOINT	VERBINDUNG
32B.08.039	MT-CH011	1	LINGUETTA 5x5x20 UNI6604-A	TONGUE	CLAVETTE	PASSFEDER
32B.08.040	MT-PE5091	1	ALBERO STERZO	STEERING WHEEL PIN	PIVOT VOLANT	LENKRADSBOLZEN
32B.08.041	MT-VP038	1	POMELLO FRENO A MANO UBF38	KNOB	POMMEAU	KUGELGRIF
32B.08.042	MT-BO5049	1	BOCCOLA SOFFIETTO STERZO	BUSH	COQUILLE SOUFFLET BAR	LENKBLASEBALGSBUCHSE
32B.08.043	MT-MV5050	1	SOFFIETTO ALB. STERZO -07907-103400	BELLOWS	SOUFFLET DU DE LA BAR	BLASEBALG
32B.08.044	MT-VE260	2	VITE ESAGONALE M8x16 UNI 5737/77	HEXAGONAL-HEADED BOLT	VIS	SECHSECKIGE SCHRAUBE
32B.08.045	MT-RO455	2	RONDELLA SPACCATA DIAM. 8 UNI 1751	WASHER	RONDELLE	SCHEIBE
32B.08.046	MT-RO204	2	RONDELLA PIANA M8	WASHER	RONDELLE	SCHEIBE
32B.08.047	MT-SC001	2	SUPPORTO CUSCINETTO PFT47	BEARING SUPPORT	SUPPORT ROULEMENT	KUGELLAGERSTUETZE
32B.08.048	MT-BO5056	1	BOCCOLA STERZO S34	STEERING WHEEL BUSH	*****	LENKBUCHSE
32B.08.049	MT-BP5055	1	PEDANA IN GOMMA S32	*****	*****	*****
32B.08.050	MT-PA5011	1	PEDANA LATERALE S32	*****	*****	*****
32B.08.051	MT-VV5001	7	VITE TESTA BOMBATA M6x16	CUP-HEADED BOLTNG	VIS BOMBEE M6X16	HALBRUNDSCHRAUBE
32B.08.052	MT-PA5010	1	PEDANA CENTRALE S32	*****	*****	*****
32B.08.054	MT-GN5010	1	GIUNTO SCAN.INT.13 EST.18 DENTI L=3	*****	*****	*****
32B.08.055	MT-VE464	2	VITE ESAGONALE M8x35 UNI 5737/77 IN	*****	*****	SECHSECKIGE SCHRAUBE
32B.08.056	MT-MI5082	1	GUAINA 4X8 L=650	SHEATH	GAINA 4X8	MANTEL
32B.08.057	MT-MI5004	1	REGOLATORE FILO FRENO M8	BRAKE WIRE REGULATOR	REG.FIL FREIN	REGLER
32B.08.058	MT-VE265	1	VITE ESAGONALE M8x40 UNI 5737/77	HEXAGONAL-HEADED BOLT	VIS	SECHSECKIGE SCHRAUBE
32B.08.059	MT-MI2501	1	CARRUCOLA D35	PULLEY	POULIE	SEILROLLE
32B.08.060	MT-ML080	1	MOLLA	SPRING	RESSORT	FEDER
32B.08.061	MT-DD205	2	DADO M8 UNI 5588/65	NUT	ECROU	MUTTER
32B.08.062	MT-IS001	1	RIVESTIMENTO PEDALE (grande)	PEDAL COVER	REVETEMENT	PEDALVERKLEIDUNG
32B.08.063	MT-LV5023	1	LEVA PEDALE FRENO	LEVER BRAKE	LEVIER FREIN	BREMSHEBEL
32B.08.064	MT-VB231	3	VITE CIL. BRUGOLA M8x20 ZINCATA	CHEESE-HEADED SCREW	VIS	ZYLINDERSCHRAUBE
32B.08.065	MT-PE070	1	PERNO FISSAGGIO STAFFA A T	PIN	PIVOT	BOLZEN
32B.08.066	MT-SG001	2	ANELLO SEEGER PER EST. D10 UNI 7435	RING	SEEGER	SEEGERRING
32B.08.067	MT-SU5023	1	SUPPORTO LEVA PEDALE FRENO	*****	*****	*****
32B.08.068	MT-MI5055	1	FUNE FRENO L=2600 C/PALLINO	BRAKE CABLE	CABLE DU FREIN	SEIL
32B.08.069	MT-MI5083	1	GUAINA 4X8 L=1175	SHEATH	GAINA 4X8 L=1175	MANTEL
32B.08.070	MT-RO204	2	RONDELLA PIANA M8	WASHER	RONDELLE	SCHEIBE
32B.08.071	MT-RO255	2	RONDELLA SPACCATA DIAM. 8 UNI 1751	WASHER	RONDELLE	SCHEIBE
32B.08.072	MT-VE262	2	VITE ESAGONALE M8x25 UNI 5137/77	SCREW	VIS	SECHSECKIGE SCHRAUBE
32B.08.073	MT-DD205	2	DADO M8 UNI 5588/65	NUT	ECROU	MUTTER

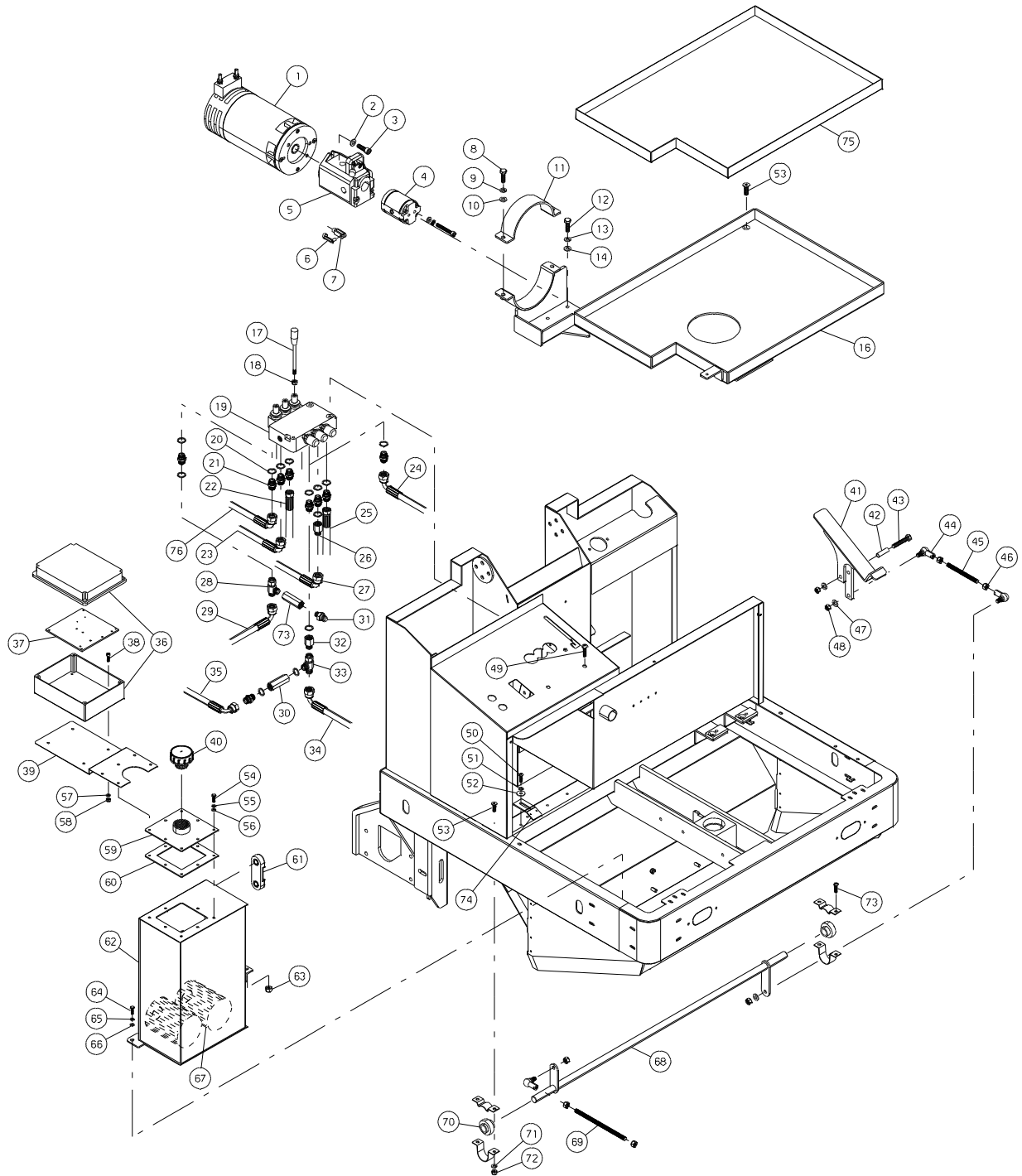

N.Position	Code Num	Qta	Descrizione	Description	Description	Bezeichnung
32B.09.001	MT-MO5039	1	MOTORE ELETTRICO	ELECTRIC ENGINE	MOTEUR ELECTRIQUE	ELEKTROMOTOR
32B.09.002	MT-RO205	2	RONDELLA NORMALE DIAM. 10 UNI 6592/	WASHER	RONDELLE	SCHEIBE
32B.09.003	MT-VE282	2	VITE ESAGONALE M10x30 UNI 5737/77	HEXAGONAL-HEADED BOLT	VIS	SECHSECKIGE SCHRAUBE
32B.09.004	MT-PO5011	1	POMPA A INGRANAGGI	GEAR PUMP	POMPE A ENGRANAGES	ZAHNRADPUMPE
32B.09.005	MT-PO5010	1	POMPA A PISTONI	PUMP	POMPE A PISTONS	KOLBENPUMPE
32B.09.006	MT-SN008	1	SNODO (forcella) M8 (lunga)	JOINT	JOINT	GELENK
32B.09.007	MT-MI157	1	CLIPS PER FORCELLA M8	CLIPS	CLIPS	GABELSKLIPP
32B.09.008	MT-VE291	2	VITE ESAGONALE M10X50 UNI 5737/77	HEXAGONAL-HEADED BOLT	VIS	SECHSECKIGE SCHRAUBE
32B.09.009	MT-RO256	2	RONDELLA SPACCATA DIAM.10 UNI 1751	WASHER	RONDELLE	SCHEIBE
32B.09.010	MT-RO205	2	RONDELLA NORMALE DIAM. 10 UNI 6592/	WASHER	RONDELLE	SCHEIBE
32B.09.011	MT-FS5008	1	FASCIA ARRESTO MOTORE ELETTRICO S32	*****	*****	*****
32B.09.012	MT-VE261	3	VITE TE M8x20	SCREW	VIS	SCHRAUBE
32B.09.013	MT-RO255	3	RONDELLA SPACCATA DIAM. 8 UNI 1751	WASHER	RONDELLE	SCHEIBE
32B.09.014	MT-RO204	3	RONDELLA PIANA M8	WASHER	RONDELLE	SCHEIBE
32B.09.015	MT-VV242	1	VITE SVASATA A BRUGOLA M8x20 UNI593	CUP-HEADED BOLT	VIS	SENKSCHRAUBE
32B.09.016	MT-TP5081	1	TELAIO PORTABATTERIE S32	*****	*****	*****
32B.09.017	MT-LV5056	3	LEVA DISTRIBUTORE	LEVER	LEVIER	HEBEL
32B.09.018	MT-DD204	3	DADO M6 UNI 5588/65	NUT	ECROU	MUTTER
32B.09.019	MT-DB5008	1	DISTRIBUTORE CON 3 LEVE UBF34 NUOVA	DISTRIBUTOR	DISTRIBUTEUR A 3 LEVI	VERTEILER
32B.09.020	MT-RO5010	10	RONDELLA IN RAME 3/8	COPPER WASHER	RONDELLE EN CUIVRE	KOPFERSCHEIBE
32B.09.021	MT-MI033	9	NIPLES M-M G3/8 G3/8	NIPPLE	NIPLES	NIPPEL
32B.09.022	MT-TU5170	1	TUBO 1/4 F90-FD L=2400	*****	*****	*****
32B.09.023	MT-TU5079	1	TUBO 1/4 F90 F90 180° L=450	PIPE	TUYAU 1/4 180°	ROHR
32B.09.024	MT-TU5195	1	TUBO 3/8 R2AT F90 F90 L=760	*****	*****	*****
32B.09.025	MT-TU5184	1	TUBO 1/4 F90-FD L=2530	*****	*****	*****
32B.09.026	MT-RC5061	1	RACCORDO COLONNETTA CORTA M1/4 F3/8	PIPE FITTING	RACCORD COLONNETTE CO	ANSCHLUSS
32B.09.027	MT-TU5080	1	TUBO 1/4 F90 F90 260° L=280	PIPE	TUYAU 1/4 F90	ROHR
32B.09.028	MT-RC5022	1	NIPLES A T 3/8 M-M.90 F.GIR.	NIPPLE	ADAPTATEUR	NIPPEL
32B.09.029	MT-TU5164	1	TUBO 3/8 F90 - F90 L=500 A 90 GRADI	*****	*****	*****
32B.09.030	MT-TO5002	1	VALVOLA VU 3/8 UNIDIREZ.	VALVE	SOUPAPE	VENTIL VU 3/8
32B.09.031	MT-RC5009	1	MINIPRESA 3/8-BSP	SOCKET	PRISE 61/4-BSP	STECKKONTAKT 61/4-BSP
32B.09.032	MT-RC5061	1	RACCORDO COLONNETTA CORTA M1/4 F3/8	PIPE FITTING	RACCORD COLONNETTE CO	ANSCHLUSS
32B.09.033	MT-RC5022	1	NIPLES A T 3/8 M-M.90 F.GIR.	NIPPLE	ADAPTATEUR	NIPPEL
32B.09.034	MT-TU066	1	TUBO 3/8 FD-F90 L=1100	*****	*****	*****
32B.09.035	MT-TU5176	1	TUBO 3/8 FD F45 L=2740	*****	*****	*****
32B.09.036	MT-SB5028	1	CASSETTA GEWISS GW44217 PER S32	*****	*****	*****
32B.09.037	MT-PT5107	1	PIASTRA ALLUM.CABL.IIMP.ELETT. S32	*****	*****	*****
32B.09.038	MT-VE244	4	VITE ESAGONALE M6x20 UNI 5737/77	HEXAGONAL-HEADED BOLT	VIS	SECHSECKIGE SCHRAUBE
32B.09.039	MT-SU5216	1	SUPPORTO GR. ELETTRICO S32B	*****	*****	*****
32B.09.040	MT-TA5015	1	TAPPO CARICO OLIO	OIL CAP	BOUCHON CHARGE-HUILE	DECKEL
32B.09.041	MT-LV5079	1	LEVA PEDALE AVANZAMENTO	LEVER	LEVIER PEDALE DEPL.	HEBEL
32B.09.042	MT-BO5043	1	BOCCOLA NYLON	NYLON BUSH	COQUILLE	NYLONBUCHSE
32B.09.043	MT-VE288	1	VITE ESAGONALE M10x70 UNI 5737/77	HEXAGONAL-HEADED BOLT	VIS	SECHSECKIGE SCHRAUBE
32B.09.044	MT-MI5066	1	SNODO ANGOLARE M10	ANGLE JOINT	JOINT ANGULAIRE	WINKELGELENK
32B.09.045	MT-MV5052	1	TRAFILA M10 L=190	DRAW	FILIERE	ZIEHEISEN
32B.09.046	MT-DD206	2	DADO M10 UNI 5588/65	NUT	ECROU	MUTTER
32B.09.047	MT-RO205	1	RONDELLA NORMALE DIAM. 10 UNI 6592/	WASHER	RONDELLE	SCHEIBE
32B.09.048	MT-DD255	1	DADO AUTOBLOCCANTE M10	SELF-LOCKING NUT	ECROU DE SURETE	SICHERUNGSMUTTER
32B.09.049	MT-VV5008	3	TCE BUTTON UNI7380 10X30 ZIN	SCREW	VIS	SCHRAUBE
32B.09.050	MT-VE261	1	VITE TE M8x20	SCREW	VIS	SCHRAUBE
32B.09.051	MT-RO204	1	RONDELLA PIANA M8	WASHER	RONDELLE	SCHEIBE
32B.09.052	MT-RO305	1	RONDELLA SLARGATA DIAM. 6x24 UNI 65	WASHER	RONDELLE	SCHEIBE
32B.09.053	MT-VV241	2	VITE SVAS. A BRUGOLA M8X25 UNI 5933	*****	*****	*****
32B.09.054	MT-VE444	8	VITE ESAGONALE M6x20 UNI 5737/77 IN	SCREW	VIS	SECHSECKIGE SCHRAUBE
32B.09.055	MT-RO254	8	RONDELLA SPACCATA DIAM. 6 UNI 1751	WASHER	RONDELLE	SCHEIBE
32B.09.056	MT-RO203	8	RONDELLA NORMALE DIAM. 6 UNI 6592/6	WASHER D6	RONDELLE	SCHEIBE
32B.09.057	MT-RO203	4	RONDELLA NORMALE DIAM. 6 UNI 6592/6	WASHER D6	RONDELLE	SCHEIBE
32B.09.058	MT-DD204	4	DADO M6 UNI 5588/65	NUT	ECROU	MUTTER
32B.09.059	MT-CO5042	1	COPERCHIO SERBATOIO OLIO IDR. S32	*****	*****	*****
32B.09.060	MT-GR5052	1	GUARNIZIONE COP.SERBATOIO OLIO IDR.	*****	*****	*****
32B.09.061	MT-MI5071	1	INDICATORE VISIVO LIVELLO OLIO	OIL LEVEL INDICATOR	INDICATEUR NIVEAU HUI	OELANZEIGER
32B.09.062	MT-SB5031	1	SERBATOIO OLIO IDR. S32	*****	*****	*****
32B.09.063	MT-DD253	1	DADO AUTOBLOCCANTE M6	SELF-LOCKING NUT	ECROU DE SURETE	SICHERUNGSMUTTER
32B.09.064	MT-VE261	1	VITE TE M8x20	SCREW	VIS	SCHRAUBE
32B.09.065	MT-RO254	1	RONDELLA SPACCATA DIAM. 6 UNI 1751	WASHER	RONDELLE	SCHEIBE
32B.09.066	MT-RO203	1	RONDELLA NORMALE DIAM. 6 UNI 6592/6	WASHER D6	RONDELLE	SCHEIBE
32B.09.067	MT-FT5021	2	FILTRO ASPIRAZIONE OLIO	OIL SUCTION FILTER	*****	OELSAUGFILTER
32B.09.068	MT-TI5028	1	ASTA COMANDO AVANZAMENTO S32	*****	*****	*****
32B.09.069	MT-MV5071	1	TRAFILA M10X????	*****	*****	*****
32B.09.070	MT-CS5012	2	CUSCINETTO SKF YAR 17-203-2F C/SUPP	*****	*****	*****
32B.09.071	MT-RO204	4	RONDELLA PIANA M8	WASHER	RONDELLE	SCHEIBE
32B.09.072	MT-DD254	4	DADO AUTOBLOCCANTE M8	SELF-LOCKING NUT	ECROU DE SURETE	SICHERUNGSMUTTER
32B.09.073	MT-VV5000	2	VITE TESTA BOMBATA M8x30	CUP-HEADED BOLT	VIS	HALBRUNDSCHRAUBE
32B.09.074	MT-PT5077	1	PIASTRINA ATTACCO INTERRUPTORE STOP	PLATE	PLAQUETTE INTERR.DE B	PLAETTCHEN
32B.09.075	MT-SB5033	1	VASCHETTA BATTERIE S32B	*****	*****	*****
32B.09.076	MT-TU5179	1	TUBO 3/8 F45 - F90 L=2710	*****	*****	*****

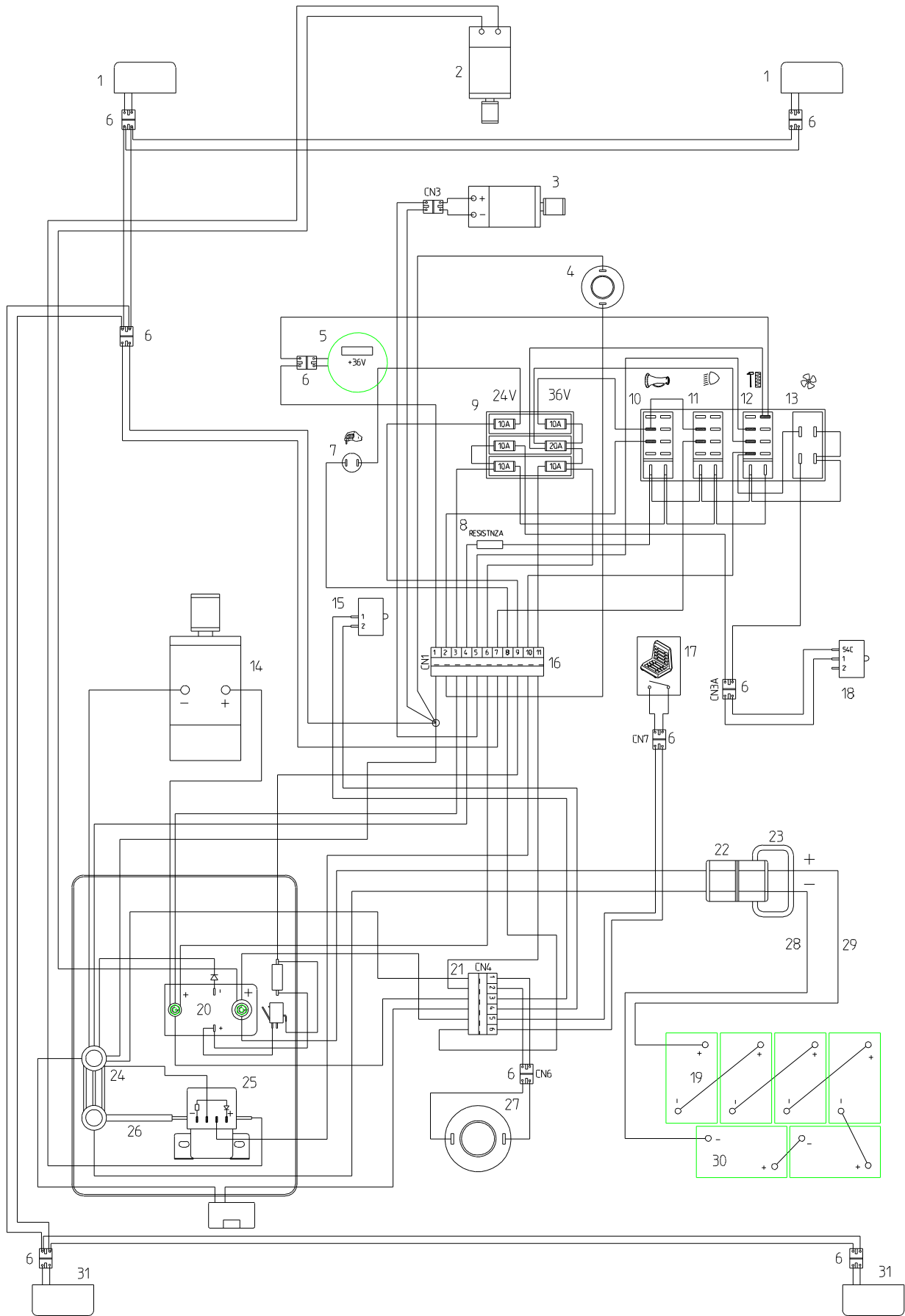



N.Position	Code Num	Qta	Descrizione	Description	Description	Bezeichnung
32B.10.001	MT-PY294	2	FANALE ANTERIORE DX/SX UBF34	FRONT LIGHT	FEUX	SCHEINWERFER
32B.10.002	MT-MO5038	1	MOTORE VENTOLA ASPIRAZIONE 36V	SUCTION FAN ENGINE 36	MOTEUR DU ROTOR	SAUGGEBLAESES MOTOR
32B.10.003	MT-MO5036	1	MOTORE SCUOTIFILTRO 36V	SHAKING FILTER ENGINE	MOTEUR SECOUEFILTRE	SCHUETTELFILTERSMOTOR
32B.10.004	MT-MI5070	1	AVVISATORE ACUSTICO 36V	HORN	CLACKSON	HUPE
32B.10.005	MT-PY5169	1	CONN. C-LINE 7P FEM.1/0480420/0	*****	*****	*****
32B.10.006	MT-PY5122	7	CONNETTORE	CONNECTOR	CONNECTEUR	STECKVERBINDER
32B.10.007	MT-PY5141	1	INTERRUTTORE A CHIAVE INTERCAMBIABI	KEY SWITCH	INTERRUPTEUR A CLEF	SCHLUESSELSCHALTER
32B.10.008	MT-PY5225	1	RESISTENZA 68 homm 5 WATT	*****	*****	*****
32B.10.009	MT-PY5143	1	SCATOLA PORTAFUS. 6 VIE	FUSE BOX	BOITE PORTE-FUSIBLES	SICHERUNGSHALTER
32B.10.010	MT-IN5085	1	INTERRUTTORE A PULSANTE	PUSH SWITCH	INTERR.A BOUTON	DRUCKKNOPFSCHALTER
32B.10.011	MT-IN5092	1	INTERRUTTORE CIAM 511.111	SWITCH	INTERR.CIAM 511.111	SCHALTER
32B.10.012	MT-IN5090	1	INTERRUTTORE CIAM 511.120	SWITCH	INTERR.CIAM 511.120	SCHALTER
32B.10.013	MT-PY5129	1	SPIA DI CONTROLLO	PILOT LIGHT	TEMOIN DE COMMANDE	PRUEFUNGSANZEIGER
32B.10.014	MT-MO5039	1	MOTORE ELETTRICO	ELECTRIC ENGINE	MOTEUR ELECTRIQUE	ELEKTROMOTOR
32B.10.015	MT-IN5094	1	INTERRUTTORE C/TIRO MOLLA	SPRING SWITCH	INTERR. TIRAGE RESSOR	FEDERSCHALTER
32B.10.016	MT-PY486	1	CONNETTORE 11 POLI MASCHIO	CONNECTOR	CONNECTEUR	STECKVERBINDER
32B.10.017	MT-MI015	1	SEDILE COMPLETO DI GUIDE	SEAT	SIEGE	SITZ
32B.10.018	MT-IN5005	1	MICRO COMANDO SPIA FLAP	MICRO	MICRO	MIKROSCHALTER
32B.10.019	MT-PY001	5	CAVO COLLEGAM. BATTERIE S=10mmq L=3	BATTERY CONNECT.CABLE	CABLE	BATTERIEKABEL
32B.10.020	MT-PY5179	1	TELERUTTORE MAC 1D 36V	REMOTE CONTROL SWITCH	TELERUPTEUR MAC 1D 36	FERNSCHALTER
32B.10.021	MT-PY267	1	CONNETTORE FEMMINA 6 P	CONNECTOR	CONNECTEUR FEMELLE	STECKERHUELSE
32B.10.022	MT-PY535	1	SPINA CARICABATTERIA SBE 160 A	BATTERY CHARGER PLUG	GOUPILLE CHARGE-BATTE	STECKER
32B.10.023	MT-PY5173	1	MANIGLIA ROSSA	RED HANDLE	POIGNEE ROUGE	ROTER GRIFF
32B.10.024	MT-PY289	1	FUSIBILE LAMELLARE 75A	FUSE	FUSIBLE	FLACHSICHERUNGEINSATZ
32B.10.025	MT-PY206	1	TELERUTTORE MAC 15D/36 C/SPEGNIPICC	REMOTE CONTROL SWITCH	TELERUPTEUR	FERNSCHALTER
32B.10.026	MT-PY244	1	FUSIBILE A NASTRO 50A 95x16	*****	*****	*****
32B.10.027	MT-PY7005	1	LAMPEGGIANTE MULTIVOLTAGGIO	BLINKER	GYROPHARE	BLINKLEUCHTE
32B.10.030	BT057	6	BATTERIA 6V 330Ah EAST PENN	BATTERY 6V 330Ah	BATTERIE 6V 330AH	*****
32B.10.031	MT-PY5139	2	FANALE POST. UBF34	TAILLIGHT	FANAL POST. UBF34	HECKLEUCHTE

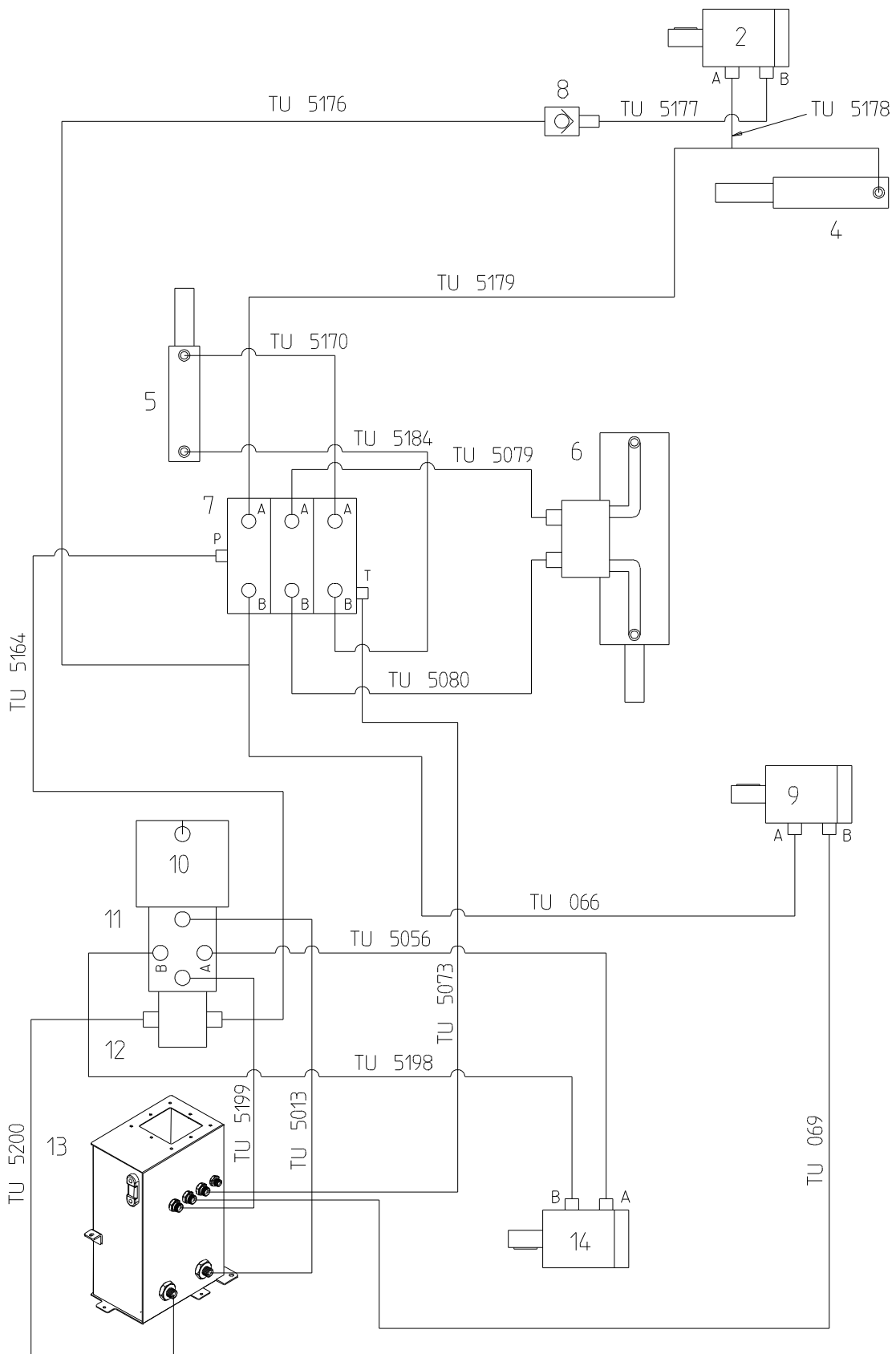

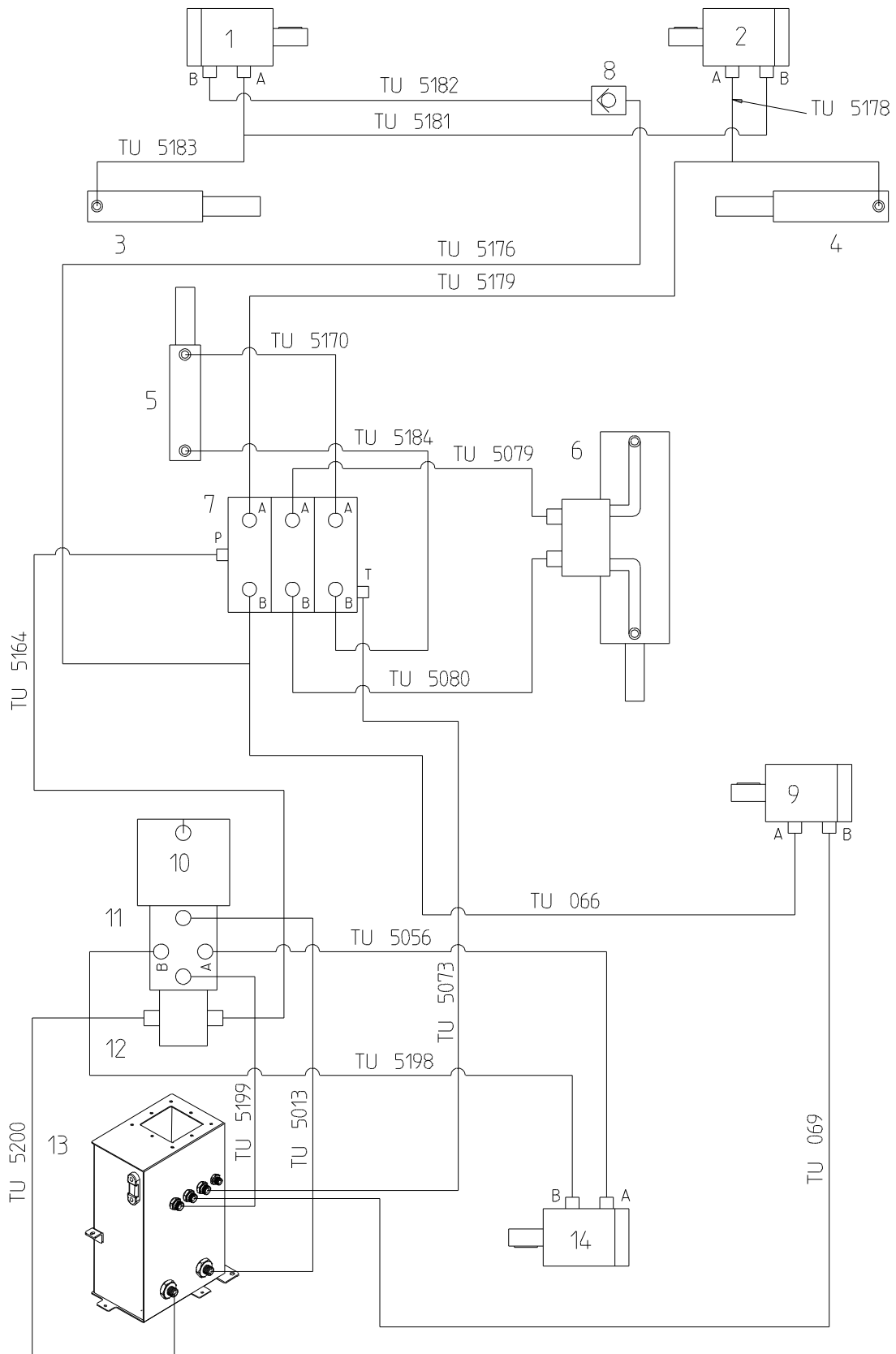



N.Position	Code Num	Qta	Descrizione	Description	Description	Bezeichnung
32B.11.001	MT-MO163	1	MOTORE SPAZZOLA LATERALE	HYDRAULIC ENGINE	MOTEUR HYDR. BROSSE	HYDROMOTOR
32B.11.002	MT-MO163	1	MOTORE SPAZZOLA LATERALE	HYDRAULIC ENGINE	MOTEUR HYDR. BROSSE	HYDROMOTOR
32B.11.003	MT-MA5021	1	MARTINETTO SPAZZ. LATERALE UBF34	SIDE BRUSH JACK	CRIC BROSSE LAT.	HEBEBOCK
32B.11.004	MT-MA5021	1	MARTINETTO SPAZZ. LATERALE UBF34	SIDE BRUSH JACK	CRIC BROSSE LAT.	HEBEBOCK
32B.11.005	MT-MA5019	1	MARTINETTO IDRAULICO FLAP UBF34	HYDRAULIC JACK	CRIC HYDRAULIQUE	HEBEBOCK
32B.11.006	MT-MA5024	1	MARTINETTO SOLLEVAMENTO CASSONE S32	*****	*****	*****
32B.11.007	MT-DB5008	1	DISTRIBUTORE CON 3 LEVE UBF34 NUOVA	DISTRIBUTOR	DISTRIBUTEUR A 3 LEVI	VERTEILER
32B.11.008	MT-TO5002	1	VALVOLA VU 3/8 UNIDIREZ.	VALVE	SOUPAPE	VENTIL VU 3/8
32B.11.009	MT-MO162	1	MOTORE SPAZZOLA CENTRALE	HYDRAULIC MOTOR	MOTEUR HYDR. BROSSE	HYDROMOTOR
32B.11.010	MT-MO5039	1	MOTORE ELETTRICO	ELECTRIC ENGINE	MOTEUR ELECTRIQUE	ELEKTROMOTOR
32B.11.011	MT-PO5010	1	POMPA A PISTONI	PUMP	POMPE A PISTONS	KOLBENPUMPE
32B.11.012	MT-PO5011	1	POMPA A INGRANAGGI	PUMP	POMPE A PISTONS	KOLBENPUMPE
32B.11.013	MT-SB5031	1	SERBATOIO OLIO IDR. S32	*****	*****	*****
32B.11.014	MT-MO5051	1	MOTORE IDRAULICO TRAZIONE	TRACTION HYDRAULIC EN	MOTEUR HYDRAULIQUE TR	HYDROANTRIEBMOTOR

fiorentini





Mat. n.
Serial no.
Nr. de serie

Data di spedizione
Date of shipment
Date de spedition

Distributed by:

ING. O. FIORENTINI s.r.l.

“THE BEST IN FLOOR MACHINES”

FILIALI:

20132 MILANO – Fax. 02/2592779

Via Palmanova 211/a – Tel. 02/27207783 - 2564810

00155 ROMA – Fax. 06/22754075

Via Carlo Carrà 13 – Tel. 06/22754040-2275060

STABILIMENTO:

50030 PIANCALDOLI (FI) – Fax. 055/817144

Loc. Rombola – Tel. 055/8173610